

CONTROL VALVE
SERIES BR12B®

SESTO  **VALVES** | Advanced
Valves Solutions

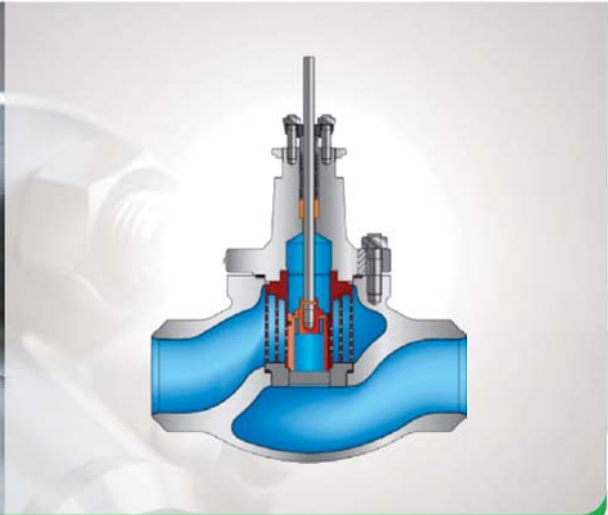

version 12/2011



BR 12B - DIRECT CONTROL VALVE

Nominal dimensions

- DN 25 - DN 250
- 1" - 10"

Nominal pressure

- PN 10 - 400
- Class 150 - Class 2500

Construction

- single seat valve with option of balanced plug and multi-step reduction of pressure drop
- metal or soft seat

Working temperature range

- -180°C to +650°C

Flow characteristic, Kvs value

- linear, equipercantage
- Kvs: 10 - 800 [m³/h]

Tightness class (IEC 60534 - 4)

- class IV - standard
- class V - optional increased
- class VI - on request (special design)

Body material

- grey cast iron, ductile iron, carbon steel, stainless steel according to EN, DIN or ASTM

Plug and seat material

- stainless steel
- stellite or plasma nitridation possibility

End connection

- flanged
- welding

Actuators

- pneumatic with diaphragm
- electro-hydraulic
- electric
- hydraulic
- manual operated

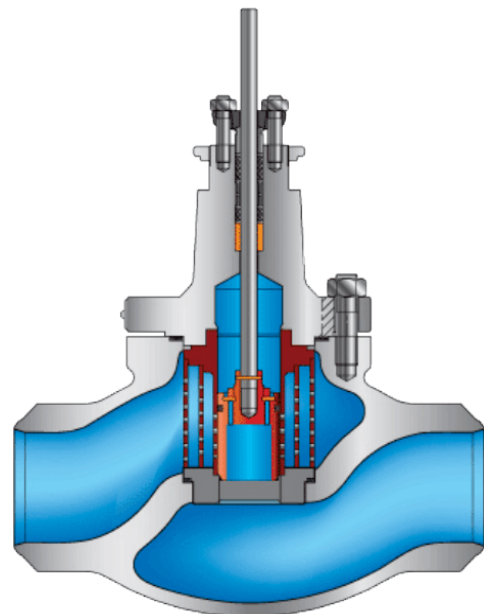



USE

Single-ported globe control valves type BR12B are used in automatic and remote control installations as flow control elements to adjust flow of liquids, steam and gases. Wide range of materials, excellent pressure and temperature parameters, multiple design variants, meeting requirements of various processes make the valves applicable under the most demanding working conditions in power generation, petroleum chemistry, heating, chemical industry, metallurgy, etc.

FEATURES

- Various materials of valve body and internal parts, adapted to specific working conditions.
- Design provides noise reduction, enhanced resistance to cavitation and flashing, and elimination of choked flow.
- Wide range of nominal dimensions in from DN25 to DN250, for nominal pressures, PN10 to CL2500
- Wide flow ratio range and various control characteristics.
- Reduction in aggressive and toxic media emissions to environment by application of bellow seal bonnets or bonnet packings meeting requirements of TA - LUFT.
- Easy assembly and dismantling of valve internal parts for maintenance and service.
- High durability and reliability due to application of top-class materials and surface improvement processes (burnishing, stelling, heat treatment, CrN coating).
- Possibility of mating with reverse action P/R (column) and P1/R1 (cast yoke) multi-spring actuators, and changing the spring range without any extra parts (keeping the number of springs).
- Possibility of fitting actuators with side-mounted (P1/R1) or top-mounted (P/R) handwheel.
- Possibility of performing diagnostics of "valve - actuator" due to application of smart electro-pneumatic positioners.
- Wide range of electric actuators.
- Special designs option:
 - for oxygen
 - for liquid and gaseous fuels
 - for low temperature fluids (liquid oxygen, nitrogen etc.)
 - for acid gases containing H₂S
 - with heating jacket
 - for potentially explosive atmospheres as per ATEX Directive 94/9/EC - ATEX
- design and production process meet the requirements of Quality Management System ISO 9001 and Directive 97/23/EC, and regulations of AD2000 Merkblatt, designated for installation on pipelines.

BR 12B® – is a trademark registered by Patent Office.

DESIGN AND TECHNICAL SPECIFICATION

Valve body (1)	single-ported, cast
Nominal size:	DN25; 40; 50; 80; 100; 150; 200; 250
Nominal pressure:	PN10; 16; 25; 40; 63; 100; 160; 250; 320; 400 as per EN 1092-1:2010 CL150; CL300; CL600; CL900; CL1500; CL2500 as per EN 1759-1:2005
divided as follows:	DN25...250 PN10...110; CL150...CL600 DN25...150 CL900; PN160 DN25...100 PN250...400; CL1500...CL2500
End connections:	– flanged: as per table 1. – butt welding ends BW, as per Table 12 and 13 – socket welding ends SW, as per Table 14

Steel flanges CL150; CL300; CL600; CL900; CL1500; CL2500 are so designed that they can be assembled with flanges as per American standards ANSI/ASME B16.5 and MSS SP44. In American standards flanges are identified with nominal values in "Classes", to which nominal pressure (PN) values as per PN-ISO 7005-1:2002 correspond.

Equivalent identifications as per PN are:

CL150: PN 20	CL300: PN 50	CL600: PN 110
CL900: PN 150	CL1500: PN 260	CL2500: PN 420

Table 1. - Flanged end connections

Nominal pressure	Facing of flange types			
	Raised face	Groove	Recess	Ring - joint
	Identification			
PN10; 16; 25; 40; 63; 100; 160; 250; 320; 400	B ³⁾	D ¹⁾	F ¹⁾	-
CL150, 300	B ³⁾	DL (D1 ²⁾)	F (F1 ¹⁾)	J (RTJ)
CL600; 900; 1500; 2500	B ³⁾ (RF)	DL (GF)	F (FF)	J (RTJ)
¹⁾ - up to PN 160 ²⁾ - only for CL300 ³⁾ - B1, Ra=12,5µm, concentric surface structure "C", B2 – (Ra as agreed with the customer) (xxx) - identification of connections as per ASME B16.5				
Possible execution of flanges per specification and indicated standards.				



- Construction length:**
- flanged valves as per PN-EN 60534-3-1; PN-M-74005; ISA S75.16-1993 Fig. 5; Table 9; 10
 - welding ends valves; Fig. 5; Tab. 11
 - as per PN-EN 60534-3-3: for PN 10...100 and CL150...600
 - as for flanged valves PN 160: for PN 160 and CL900
 - as for flanged valves PN 400: for PN 250...400 and CL1500...2500
- Materials:**
- as per Table 2; Relationship between working pressure and temperature as per Table 3.1 - 3.7
- Bonnet (2):**
- standard • extended • bellows (PN10...40; CL150...300)
- Plug (3a, b, c):**
- type: piston, sleeve guided, hard. Rangeability 50:1
 - variants: unbalanced
balanced (from DN40 / Kvs25)
balanced with pilot (DN50 / Kvs40)
 - flow characteristics: equal percentage - P
linear - L
- Seat (4):**
- fitted-in and sealed with body, hard (tight seat after consulting the manufacturer)
- Plug stem (5):**
- burnished, polished sealing face
- Control cage (6A):**
- perforated element executing preset flow characteristics and fixing the seat.
- Choke cage (6B, C):**
- perforated valve seat fixture, causing reduction in pressure drop between seat and plug.
- Body gasket (7), Seat gasket (8) and Control cage gasket (9):**
- spiral, graphite+1.4404 in all executions.
- Stem packing (9):**
- PTFE-V packing, compressed with spring bolt (Fig. 1e - item no 17)
 - ring gaskets formed in braided packing cords (PTFE +GRAPHITE)
 - graphite kits (expanded and silky graphite) or gaskets formed in braided graphite cords
 - TA-LUFT sealing with PTFE-V packing kit or graphite kit; packing structure as per Fig. 1 and 2, range of applications as per Table 3
- Leakage class:**
- basic: (class IV) less than 0,01% Kvs
 - enhanced: (class V) $3 \cdot 10^{-4} \cdot D \cdot \Delta p$ [cm³/min]
- where D (mm) - is seat diameter as per Table 5, Δp [MPa] – actual pressure drop in closed valve.
- Fluid flow direction:** Under the plug for valves as per Fig. 1a and 1b, over the plug for valves as per Fig. 1 c
- Flow coefficients:**
- as per Table 4

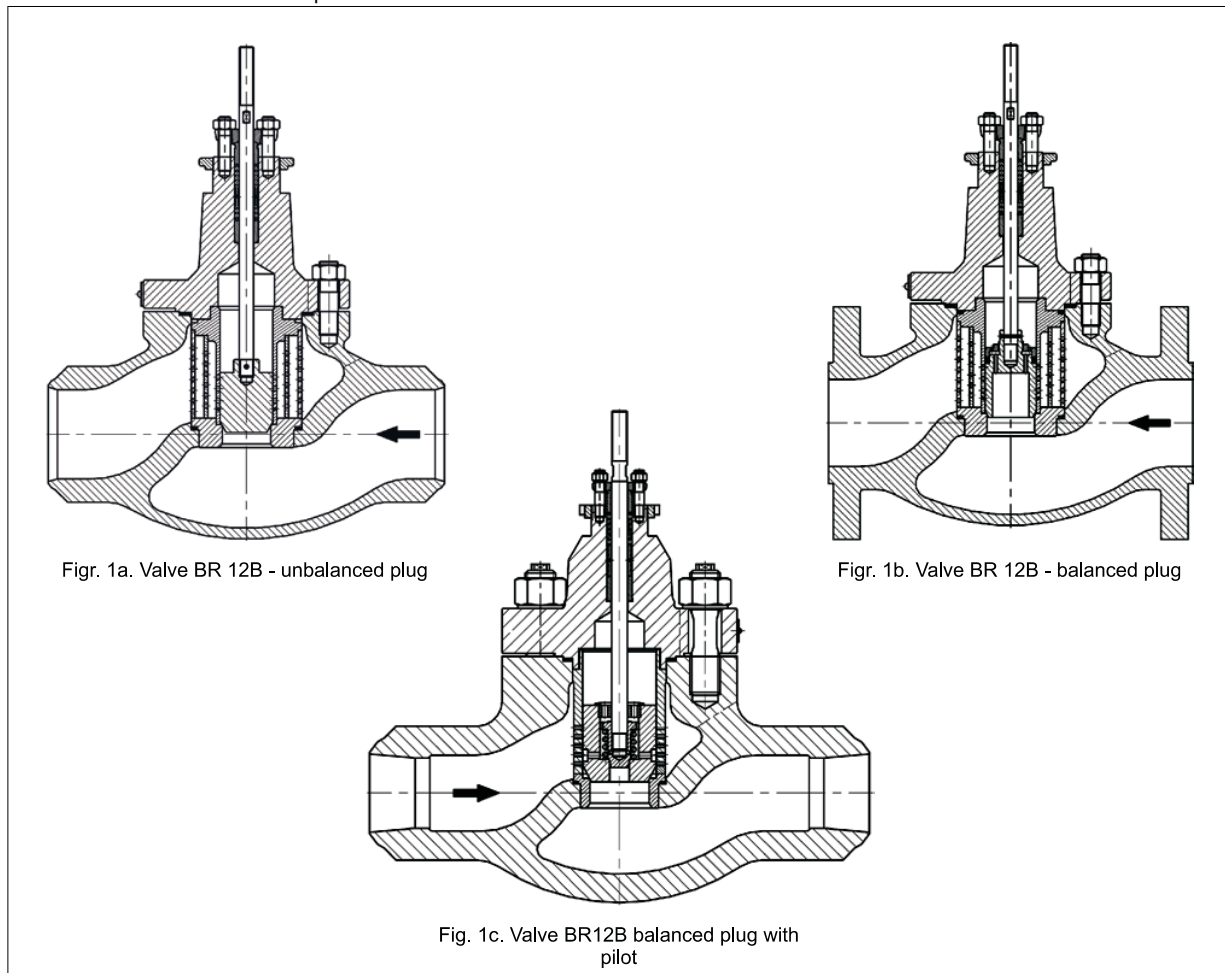

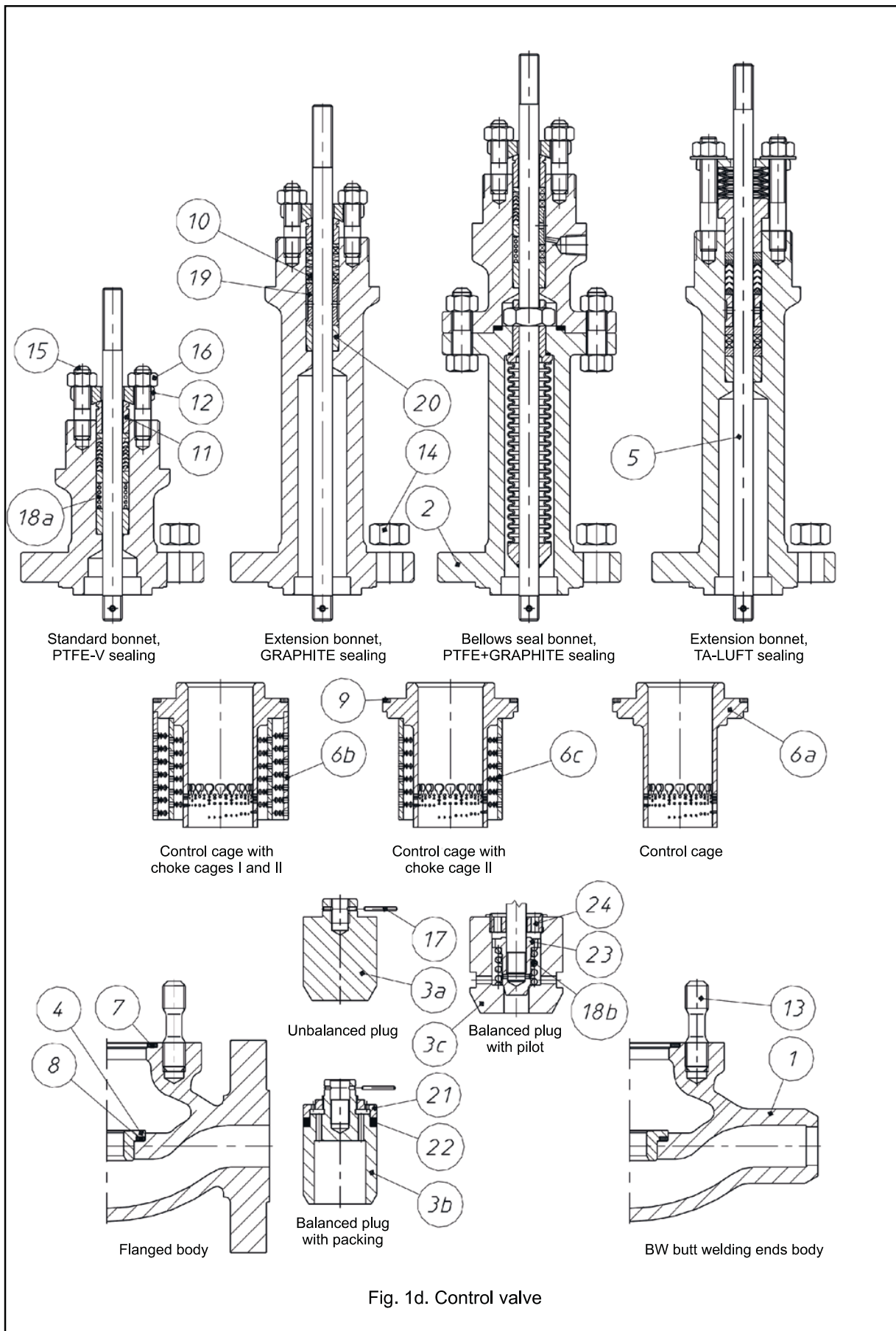



Table 2. Part list with materials.

Item	Part name		Material		
1	Body		GP 240 GH ; (1.0619) WCB	G17CrMo 9-10 ; (1.7379) WC9	G20Mn5 ; (1.6220) GX5CrNiMo 19-11-2 ; (1.4408) CF8M
2	Bonnet	DN25...50	S 355 J2G3 (1.0570)	13CrMo4-4 ; (1.7335)	P355NL2 ; (1.1106)
		DN80...250	GP 240 GH ; (1.0619) WCB	G17CrMo 9-10 ; (1.7379) WC9	G20Mn5 ; (1.6220)
3a, b	Unbalanced and balanced plug		X6CrNiMoTi 17-12-2; (1.4571) + stellite + CrN X17CrNi 16-2; (1.4057) + heat treatment		
3c	Balanced plug with pilot		X17CrNi 16-2 ; (1.4057) + heat treatment		
4	Seat		X6CrNiMoTi 17-12-2; (1.4571) X6CrNiMoTi 17-12-2; (1.4571) + stellite X17CrNi 16-2; (1.4057) + heat treatment		
5	Stem		X6CrNiMoTi 17-12-2; (1.4571) X6CrNiMoTi 17-12-2; (1.4571) + stellite + CrN X17CrNi 16-2; (1.4057) + heat treatment		
6A	Control cage		X6CrNiMoTi 17-12-2; (1.4571) X17CrNi 16-2; (1.4057) + heat treatment		
6B	Choke cage I				
6C	Choke cage II				
7	Body gasket		GRAPHITE (98%) + 1.4404 (spiral)		
8	Seat gasket				
9	Control cage gasket				
10	Packing kit		PTFE + GRAPHITE		
			PTFE „V“ (rings)		
			GRAPHITE		
11	Pressing sleeve		X6CrNiMoTi 17-12-2; (1.4571)		
12	Pressing lever		S 355 J2G3 ; (1.0570)		
13	Body screw	PN10...CL300	8.8	A4 - 70 *)	
		PN63...CL2500	42CrMo4 (1.7225)	21CrMoV5-7 (1.7709)	X6NiCrTiMoVB 25-15-2 (1.4980)
14	Body nut	PN10...CL300	8.8	A4 - 70 *)	
		PN63...CL2500	42CrMo4 (1.7225)	21CrMoV5-7 (1.7709)	X6NiCrTiMoVB 25-15-2 (1.4980)
15	Bonnet screw		8.8	A4 - 70 *)	
16	Bonnet nut		8.8	A4 - 70 *)	
17	Notched pin		X6CrNiMoTi 17-12-2; (1.4571)		
18a, b	Spring		12R10 (SANDVIK), 9Ru10; (1.4568) (SANDVIK); Nimonic 90; (2.4969)		
19	Spacer sleeve		X6CrNiMoTi 17-12-2; (1.4571)		
20	Guide bushing		X6CrNiMoTi 17-12-2; (1.4571) + stellite + CrN X17CrNi 16-2; (1.4057) + heat treatment		
21	Plug nut		X6CrNiMoTi 17-12-2; (1.4571)		
22	Plug sealing ring		Expanded graphite		
23	Pilot		X105CrMo17; (1.4125)		
24	Back nut		X6CrNiMoTi 17-12-2; (1.4571)		
Material			Relevant material standard		
GP 240 GH ; (1.0619)			EN 10213-2		
WCB			ASTM A 216		
G20Mn5 ; (1.6220)			EN 10213-3		
G17CrMo 9-10 ; (1.7379)			EN 10213-2		
WC9			ASTM A 217		
GX5CrNiMo 19-11-2 ; (1.4408)			EN 10213-4		
CF8M			ASTM A 351		
S 355 J2G3 ; (1.0570)			EN 10025		
P355 NL2 ; (1.1106)			EN 10028-3		
13CrMo4-4; (1.7335)			EN 10028		
X6CrNiMoTi 17-12-2 ; (1.4571)			EN 10088		
X17CrNi 16-2 ; (1.4057)			EN 10088		
X105CrMo17; (1.4125)			EN 10088		
C45 (1.0503)			EN 10083-1		
X30Cr13 (1.4028)			EN 10088		
8.8			EN 20898-1		
A4-70 *)			EN ISO 3506-2		
42CrMo4 (1.7225)			EN 10269		
21CrMoV5-7 (1.7709)			EN 10269		
X6NiCrTiMoVB 25-15-2 (1.4980)			EN 10269		

Note:

*) to be applied for nominal pressures PN10...CL600

Hardening of valve internal surfaces comprises:

- a) stellite – padding of surfaces with stellite: ~40HRC
- b) CrN coating – introducing chromium nitride to external layer of detail, to the depth of ca.0.1 mm:~950HV
- c) heat treatment: valve plug (~45HRC), valve seat (~35HRC), stem (~35HRC), cages (~35HRC), guide sleeve (~45HRC), pilot (~55HRC)



Tables 3.1 - 3.7, MAX Allowable working overpressure for materials at proper temperatures.

Table 3.1

Material: GP240GH (1.0619) as per EN 10213-2									
PN/CL	Standard	Temperature [°C]							
		-10...50	100	150	200	250	300	350	400
Maximum working pressure [bar]									
PN10	EN 1092-1	10	9,2	8,8	8,3	7,6	6,9	6,4	5,9
PN16		16	14,8	14	13,3	12,1	11	10,2	9,5
CL150	EN 1759-1	17,3	15,4	14,6	13,8	12,1	10,2	8,4	6,5
PN25	EN 1092-1	25	23,2	22	20,8	19	17,2	16	14,8
PN40		40	37,1	35,2	33,3	30,4	27,6	25,7	23,8
CL300	EN 1759-1	45,3	40,1	38,1	36	32,9	29,8	27,8	25,7
PN63	EN 1092-1	63	58,5	55,5	52,5	48	43,5	40,5	37,5
PN100		100	92,8	88	83,3	76,1	69	64,2	59,5
CL600	EN 1759-1	90,5	80,2	76,1	72	65,8	59,7	55,5	51,4
CL900		136	120	114	108	98,7	89,5	83,3	77,1
PN160	EN 1092-1	160	148,5	140,9	133,3	121,9	110,4	102,8	95,2
PN250		250	232,1	220,2	208,3	190,4	172,6	160,7	148,8
CL1500	EN 1759-1	226	201	190	180	165	149	139	129
PN320	EN 1092-1	320	297,1	281,9	266,6	243,8	220,9	205,7	190,4
PN400		400	371,4	352,3	333,3	304,7	276,1	257,1	238
CL2500	EN 1759-1	377	334	317	300	274	249	231	214

Table 3.2

Material: G17CrMo 9-10 (1.7379) as per EN 10213-2																		
PN/CL	Standard	Temperature [°C]																
		-10..50	100	150	200	250	300	350	400	425	450	475	500	510	520	530	540	550
Maximum working pressure [bar]																		
PN10	EN 1092-1	10	10	10	10	10	10	9,7	9,2	9	8,8	7,6	6,4	5,6	4,9	4,2	3,7	3,2
PN16		16	16	16	16	16	16	15,6	14,8	14,4	14	12,1	10,2	8,9	7,8	6,8	5,9	5,1
CL150	EN 1759-1	19,5	17,7	15,8	14	12,1	10,2	8,4	6,5	5,6	4,7	3,7	2,8	2,4	2	1,7	1,4	-
PN25	EN 1092-1	25	25	25	25	25	25	24,4	23,2	22,6	22	19	16	14	12,2	10,7	9,2	8
PN40		40	40	40	40	40	40	39	37,1	36,1	35,2	30,4	25,7	22,4	19,6	17,1	14,8	12,9
CL300	EN 1759-1	51,7	51,5	50,2	48,3	46,3	42,8	40,2	36,6	35,1	33,8	31,7	28,2	26,6	23,5	20,6	17,8	15,5
PN63	EN 1092-1	63	63	63	63	63	63	61,5	58,5	57	55,5	48	40,5	35,4	30,9	27	23,4	20,4
PN100		100	100	100	100	100	100	97,6	92,8	90,4	88	76,1	64,2	56,1	49	42,8	37,1	32,3
CL600	EN 1759-1	103	103	100	96,7	92,6	85,7	80,4	73,1	70,2	67,6	63,3	56,4	53,3	47,1	41,1	35,7	31,1
CL900		155	155	151	145	139	129	121	110	105	101	95	84,6	79,9	70,6	61,7	53,5	46,6
PN160	EN 1092-1	160	160	160	160	160	160	156,1	148,5	144,7	140,9	121,8	102,8	88,9	78,4	68,5	59,4	51,8
PN250		250	250	250	250	250	250	244	232,1	226,1	220,2	190,4	160,7	140,4	122,6	107,1	92,8	80,9
CL1500	EN 1759-1	259	258	251	242	232	214	201	183	175	169	158	141	133	118	103	89,1	77,7
PN320	EN 1092-1	320	320	320	320	320	320	312,3	297,1	289,5	281,9	243,7	205,7	179,8	156,9	137,1	118,8	103,6
PN400		400	400	400	400	400	400	390,4	371,4	361,8	352,3	304,7	257,1	224,7	196,1	171,4	148,5	129,5
CL2500	EN 1759-1	431	429	418	403	386	357	335	305	292	282	264	235	222	196	171	149	130



Table 3.3

Material: GX5CrNiMo 19-11-2 (1.4408) as per PN-EN 10213-4																			
PN/CL	Standard	Temperature [°C]																	
		-10..50	100	150	200	250	300	350	400	425	450	475	500	510	520	530	540	550	600
Maximum working pressure [bar]																			
PN10	EN 1092-1	10	10	9	8,4	7,9	7,4	7,1	6,8	-	6,7	-	6,6	-	-	-	-	6,5	5,6
PN16		16	16	14,5	13,4	12,7	11,8	11,4	10,9	-	10,7	-	10,5	-	-	-	-	10,4	8,9
CL150	EN 1759-1	17,9	16,3	14,9	13,5	12,1	10,2	8,4	6,5	5,6	4,7	3,7	2,8	2,4	2	1,7	1,4	-	-
PN25	EN 1092-1	25	25	22,7	21	19,8	18,5	17,8	17,1	-	16,8	-	16,5	-	-	-	-	16,3	14
PN40		40	40	36,3	33,7	31,8	29,7	28,5	27,4	-	26,9	-	26,4	-	-	-	-	26	22,4
CL300	EN 1759-1	63	63	57,3	53,1	50,1	46,8	45	43,2	-	42,4	-	41,7	-	-	-	-	41,1	35,4
PN100	100	100	100	90,9	84,2	79,5	74,2	71,4	68,5	-	67,3	-	66,1	-	-	-	-	65,2	56,1
CL600	EN 1759-1	93,4	85	77,8	70,6	65,8	61	57,6	55,2	54,5	53,8	53,3	52,8	52,6	44,9	44,8	44,6	44,4	-
CL900		140	127	117	106	98,6	91,4	86,4	82,8	81,7	80,6	79,9	79,2	78,9	67,4	67,1	66,9	66,7	-
PN160	EN 1092-1	160	160	145,5	134,8	127,2	118,8	114,2	109,7	-	107,8	-	105,9	-	-	-	-	104,3	89,9
PN250		250	250	227,3	210,7	198,8	185,7	178,5	171,4	-	168,4	-	165,4	-	-	-	-	163	140,4
CL1500	EN 1759-1	233	212	194	176	164	152	144	138	136	134	133	132	132	112	112	111	111	-
PN320	EN 1092-1	320	320	291	269,7	254,4	237,7	228,5	219,4	-	215,6	-	211,8	-	-	-	-	208,7	179,8
PN400		400	400	363,8	337,1	318	297,1	285,7	274,2	-	269,5	-	264,7	-	-	-	-	260,9	224,7
CL2500	EN 1759-1	389	354	324	294	274	254	240	230	227	224	222	220	219	187	187	186	185	-

Table 3.4

Material: G20Mn5 (1.6220) as per PN-EN 10213-3							
PN/CL	Standard	Temperature [°C]					
		-10..50	100	150	200	250	600
Maximum working pressure [bar]							
PN10	-	6	6	3,8	3,6	3,48	3,4
PN16		16	16	10,1	9,6	9,28	9,07
PN25		25	25	15,8	15	14,5	14,2
PN40		40	28	28	27	26	25
PN 63		63	59	58	55	53	51
PN100		100	95	92	87	85	82
PN160		160	152	148	140	136	132

Table 3.5

Material: WCB as per ASTM A216										
PN/CL	Standard	Temperature [°C]								
		-10..50	100	150	200	250	300	350	375	400
Maximum working pressure [bar]										
PN10	EN 1092-1	10	10	9,7	9,4	9	8,3	7,9	7,7	6,7
PN16		16	16	15,6	15,1	14,4	13,4	12,8	12,4	10,8
CL150	EN 1759-1	19,3	17,7	15,8	14	12,1	10,2	8,4	7,4	6,5
PN25	EN 1092-1	25	25	24,4	23,7	22,5	20,9	20	19,4	16,9
PN40		40	40	39,1	37,9	36	33,5	31,9	31,1	27
CL300	EN 1759-1	50	46,4	45,1	43,9	41,8	38,9	36,9	36,6	34,6
PN63	EN 1092-1	63	63	61,5	59,6	56,8	52,7	50,3	49	42,5
PN100		100	100	97,7	94,7	90,1	83,6	79,8	77,8	67,5
CL600	EN 1759-1	100,1	92,8	90,6	87,8	83,6	77,5	74	72,9	69,1
CL900		150,1	139,2	135,7	131,4	125,1	116,1	110,8	109,5	103,4
PN160		159,2	147,6	143,9	139,4	132,7	123,1	117,5	116,1	109,7
PN250		241,4	223,5	217,8	211,2	201,1	186,6	178,1	175,8	166,2
CL1500		250,5	231,9	226	219,2	208,7	193,6	184,8	182,4	172,5
PN320		313	289,9	282,6	273,9	260,8	242	231	227,9	215,6
PN400		396,4	367,3	358	346,9	330,3	306,6	292,6	288,6	273,1
CL2500		417,2	386,6	376,9	365,1	347,7	322,7	308	303,8	287,5



Table 3.6

Material: WC9 as per ASTM A217																				
PN/CL	Standard	Temperature [°C]																		
		-10.50	100	150	200	250	300	350	375	400	425	450	475	500	510	520	525	530	540	550
Maximum working pressure [bar]																				
PN10	EN 1092-1	10	10	10	10	10	10	10	10	9,9	9,7	9,5	7,3	5,5	5	4,4	-	3,9	3,4	2,9
PN16		16	16	16	16	16	16	16	16	16	15,9	15,6	15,3	11,7	8,9	8	7,1	-	6,2	5,4
CL150	EN 1759-1	19,5	17,7	15,8	14	12,1	10,2	8,4	7,4	6,5	5,6	4,6	3,7	2,8	-	-	1,9	-	1,3	-
PN25	EN 1092-1	25	25	25	25	25	25	25	25	24,8	24,4	23,9	18,3	14	12,6	11,2	-	9,8	8,5	7,4
PN40		40	40	40	40	40	40	40	40	39,7	39	38,3	29,2	22,3	20,2	18	-	15,7	13,6	12
CL300	EN 1759-1	51,7	51,5	50,3	48,7	46,3	42,9	40,4	38,9	36,5	35,2	33,7	31,7	27,7	-	-	21,6	-	-	15,3
PN63	EN 1092-1	63	63	63	63	63	63	63	63	62,5	61,5	60,3	46	35,2	31,9	28,3	-	24,8	21,4	18,8
PN100		100	100	100	100	100	100	100	100	99,2	97,6	95,6	73,1	55,9	50,6	44,9	-	39,3	34	29,9
CL600	EN 1759-1	103,4	103,1	100,3	97,5	92,7	85,7	80,4	77,6	73,3	70,2	67,7	63,4	55,7	-	-	43,3	-	-	30,7
CL900		155,1	154,6	150,6	146,2	139	128,6	120,7	116,5	109,8	105,4	101,4	95,1	83,4	-	-	64,9	-	-	46
PN16		164,5	163,9	159,5	154,7	147,4	136,4	128	123,6	116,5	111,8	107,6	100,8	87,3	-	-	68,9	-	-	48,8
PN250		249,2	248,1	239,8	231,2	222,6	206,6	193,8	187	176,4	169,2	162,9	152,5	122,2	-	-	104,4	-	-	74,1
CL1500		258,6	257,7	250,8	244	231,8	214,4	201,1	194,1	183,1	175,6	169,1	158,2	138,9	-	-	108,4	-	-	76,9
PN320		323,2	321,9	312,3	302,3	289,2	268	251,4	242,5	228,8	219,4	211,4	197,8	165,7	-	-	135,4	-	-	96
PN400		409,4	408	397,1	385,7	366,8	339,4	318,5	307,1	289,7	277,9	267,7	250,7	218,5	-	-	171,5	-	-	121,5
CL2500		430,9	429,5	418,3	406,5	386,2	357,2	335,3	323,2	304,9	292,5	281,8	263,9	231,7	-	-	180,5	-	-	127,9

Table 3.7

Material: CF8M as per ASTM A351																								
PN/CL	Standard	Temperature [°C]																						
		-10.50	100	150	200	250	300	350	375	400	425	450	475	500	510	520	525	540	540	550	575	600	625	649
Maximum working pressure [bar]																								
PN10	EN1092-1	8,9e	7,8	7,1	6,6	6,1	5,8	5,6	5,5	5,4	5,4	5,3	5,3	5,2	5,2	5,2	-	5,2	5,1	5,1	4,7	3,8	-	-
PN16		14,3	12,5	11,4	10,6	9,8	9,3	9	8,8	8,7	8,6	8,5	8,5	8,4	8,3	8,3	-	8,3	8,3	8,2	7,6	6,1	-	-
CL150	EN1759-1	18,4	16	14,8	13,6	12	10,2	8,4	7,4	6,5	5,6	4,6	3,7	2,8	-	-	1,9	-	1,4	-	-	-	-	
PN25	EN1092-1	22,3	19,5	17,8	16,5	15,5	14,6	14,1	13,8	13,6	13,5	13,4	13,3	13,2	13,1	13,1	-	13	13	12,9	12	9,6	-	-
PN40		35,6	31,3	28,5	26,4	24,7	23,4	22,6	22,1	21,8	21,6	21,4	21,2	21	21	20,9	-	20,8	20,8	20,7	19,1	15,5	-	-
CL300	EN1759-1	48,1	42,3	38,6	35,8	33,5	31,6	30,4	29,6	29,3	29	29	28,7	27,3	-	-	25,2	-	-	24	22,9	19,9	15,7	12,8
PN63	EN1092-1	56,1	49,2	44,9	41,6	38,9	36,9	35,5	34,9	34,4	34	33,7	33,5	33,2	33	32,9	-	32,8	32,7	32,6	30,2	24,4	-	-
PN100		89,1	78,1	71,3	66	61,8	58,5	56,4	55,3	54,5	54	53,4	53,1	52,6	52,4	52,2	-	52,1	51,9	51,7	47,9	38,7	-	-
CL600	EN1759-1	96,3	84,5	77,1	71,2	66,7	63,1	61	59,8	58,9	58,3	57,7	57,3	54,8	-	-	50,6	-	-	47,8	45,5	39,8	31,7	25,5
CL900		144,4	126,8	115,6	107	100,2	95	91,3	89,7	88,2	87,3	86,6	86	82,1	-	-	75,9	-	-	71,8	68,3	59,7	47,5	38,3
PN16		153,1	134,4	122,6	113,5	106,3	100,7	96,8	95,1	93,6	92,6	91,8	91,2	87,1	-	-	80,5	-	-	76,2	72,5	63,3	50,4	40,3
PN250		231,9	203,3	185,4	171,9	160,9	152,4	146,7	143,9	141,7	140,3	139,1	138,1	131,7	-	-	121,8	-	-	115,4	109,8	95,9	76,3	61
CL1500		240,6	210,9	192,4	178,4	167	158,1	152,2	149,3	147,1	145,6	144,3	143,3	136,7	-	-	126,4	-	-	119,8	114	99,5	79,2	63,8
PN320		300,8	263,7	240,6	223	208,7	197,6	190,3	186,7	184	182,1	180,3	179,2	170,9	-	-	158	-	-	149,7	142,5	124,4	98,9	79,2
PN400		381	334,1	304,8	282,4	264,2	250,3	241,1	236,5	233,1	230,7	228,4	227	216,6	-	-	200,2	-	-	189,5	180,5	157,7	125,1	100,4
CL2500		401	351,7	320,8	297,2	278,1	263,5	253,8	249	245,4	242,9	240,4	238,9	228	-	-	210,7	-	-	199,5	190	166	131,7	106,5



DESIGN

Single-ported globe control valves BR 12B are recommended for application under heavy-duty working conditions, with excessive noise, flashing or choked flow. Selection of designs and materials depends on working conditions. It is based on computer-aided calculations of flow coefficients, noise level, fluid status, and effectiveness of such actions depend on data submitted by customer.

Application of perforated control elements allows noise reduction by 10dBA regarding execution with contoured plug. Further noise reduction (by 5 dBA) can be achieved by application of choke cage, which causes reduction in pressure drop between plug and seat. Such design is also recommended in case of choked flow, cavitation and flashing.

Perforated structures feature higher pressure recovery coefficient FL, which allows achievement of higher flow at same Kvs and Δp as in basic design. Customers shall also appreciate possibility of achieving maximum flow ratio for all nominal sizes and control characteristics, and reduction in actuator costs due to application of balanced plugs. In case of compressive media it is advisable to apply diffusers at the valve outlet. In justified cases (noise, choked flow) diffusers can be fitted with additional perforated choke structures in the form of plates assembled between flanges or welded in diffuser interior.

On customer's request, also when flow conditions justify such solution, special executions are recommended concerning materials, flow ratios, control characteristics, leakage class, etc.

Table 4 - Packing types with application ranges.

Packing type	PN	Temperature [°C]		
		Bonnet type		
		Standard	Extended	Bellows
PTFE-V	up to CL600)*	-46...+200	-198...-46 +200...+300	-100...+200
PTFE + Graphite				
PTFE-V / TA-LUFT				
Graphite	up to CL2500)*	+200...+300	+300...+537 ,(+650)**	+200...+400
Graphite / TA-LUFT				

)* PN10...40; CL150...3000 for below seal bonnet

)** - for welding ends valves

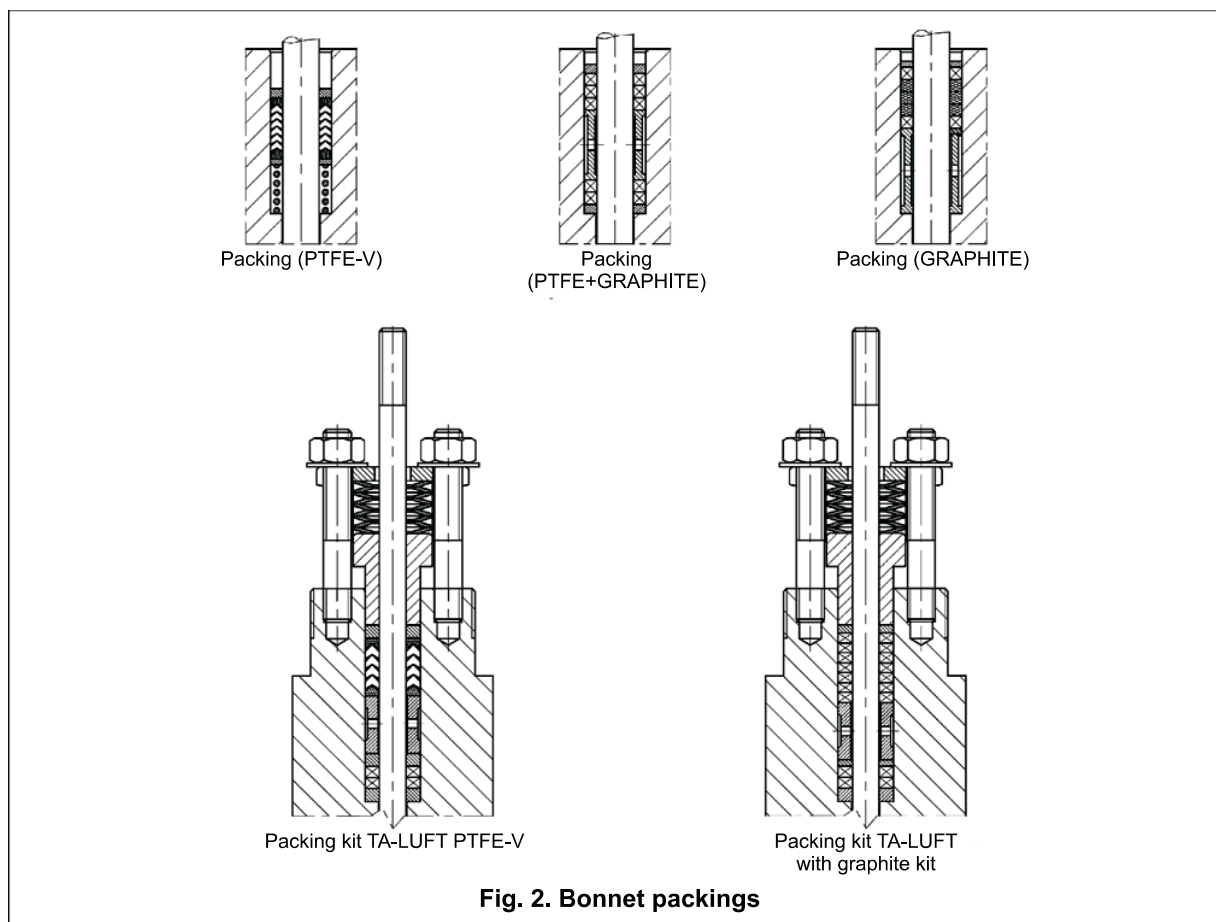



Fig. 2. Bonnet packings



Table 5.: Flow ratios Kvs [m³/h]

Kvs [m³/h]		Stroke [mm]	Seat size D [mm]	A [cm³]	F _D [kN]									
L	P				cl. IV	cl. V	25	40	50	80	100	150	200	250
10		20	20,64	3,3	0,33	2,1	• K1 **)	K2	K2					
16			25,25	5,0	0,4	2,6		K1	K2					
25			31,72	7,9	0,5	3,3		• K1	K1	K2				
40		38	41,25	13,4	0,7	4,6			• K1	K2	K2			
63			50,8	20,3	0,8	5,2				K1	K2	K2		
94			66,7	34,9	1,1	7,2				• K0	K1	K2	K2	
125		50	88,9	62,1	1,4	9,1					• K1	K2	K2	K2
160														• K1
200		63	107,92	91,5	1,7	11						K1	K2	K2
250														
320		80	126,95	126,6	2,0	13						K1	K2	K2
500		100	158,72	197,9	2,5	16							K1	K2
630			203,2	324,3	3,2	21								K1
800	-													K1
Calculation coefficients:														
FL=0,95 ; XT=0,78; Fd=0,1; xFz=0,75														

Note:1.  - no executions for PN250...CL2500

2. **) – for PN10...50 - K0

3. „K“ – maximum number of choke cages in valve:

K0 – no choke cages

4. The number of choked cages does not concern

K1 – one no choke cage

the valves balanced by a pilot

K2 – two choke cages

**ALLOWABLE PRESSURE DROPS.**

Pressure drops Δp [bar] apply to closed valve and they are calculated with account for the valve drive performance. Actual pressure drops should not exceed 70% of allowable working pressure for given nominal pressure, material execution and working temperature, as per tables 3.1 to 3.7.

$$\Delta p = \frac{10 (F_s - F_D)}{A}$$

where: Δp [MPa] – calculated pressure drop
 F_s [kN] – actuator available force (tab. 6)
 F_D [kN] – valve plug to valve seat pressure (tab. 5)
 A – surface coefficient of seat diameter D [cm²];
 D – seat diameter [mm] (tab. 5)

$$A = \frac{\pi D^2}{400} \text{ [cm}^2\text{]}$$

Note:

1. Valves with balanced plug and with gasket are manufactured only in leakage class IV. For balanced plugs assume the available force of FS at least equal to FD for class V (Table 5).
2. For valves relieved with a remote control, drive disposition forces need to be agreed on with the manufacturer.

Table 6. Available force F_s [kN] of pneumatic actuators

Actuator size	Actuator with direct action P; P1			Actuator with reverse action R					
	Supply pressure [kPa]			Spring range [kPa]					
	140	250	400	20 - 100	40 - 120; 40 - 200	60 - 140	80 - 240	120 - 280	180 - 380
160	0,64	2,4	4,8	0,32	0,64	0,96	1,28	1,92	-
250	1,0	3,8	7,5	0,5	1,0	1,5	2,0	3,0	-
400	1,6	6,0	12,0	0,8	1,6	2,4	3,2	4,8	-
630	2,5	9,5	18,9	1,3	2,5	3,8	5,0	7,6	11,3
R-630T	-	-	-	2,6	5,0	7,6	10,0	15,2	22,6
1000	4,0	15,0	30,0	2,0	4,0	6,0	8,0	12,0	18,0
1500	6,0	22,5	45,0	3,0	6,0	9,0	12,0	18,0	27,0
1500T	12,0	45,0	90,0	6,0	12,0	18,0	24,0	36,0	54,0

Note:

1. For direct action actuators P, P1 adopted spring range is 20 - 100kPa.
2. For electric and other actuators, Δp value can be calculated from the above equation and from the data in tables 5 and 6 with the available force FS provided to be the actuator capacity rating to its catalogue card.

Table 7. Pressure drops Δp [MPa] for valves with pneumatic actuators, seat leakage class IV and V.

Seat diameter [mm]	Actuator size	Air-to-close, actuators P/P1 Spring range 20...100 kPa						Air-to-open, actuators R/R1											
		Class IV			Class V			Class IV						Class V					
		Supply pressure [kPa]						Spring range [kPa]						Spring range [kPa]					
		140	250	400	140	250	400	20...100	40...120 40...200	60...140	80...240	120...280	180...380	20...100	40...120 40...200	60...140	80...240	120...280	180...380
		Δp [bar]																	
20,64	160	9	62	133	-	7	79	-	9	19	28	47	-	-	-	-	-	-	
	250	20	100	210	-	48	159	5	20	34	49	78	-	-	-	-	26	-	
	400	37	166	280	-	115	280	14	37	60	84	131	-	-	-	9	32	79	
	630	65	272	280	11	218	280	27	65	103	140	216	280	-	11	49	86	162	
	R-630T	-	-	-	-	-	-	65	140	216	280	280	280	11	86	162	237	280	
25,25	160	4	40	87	-	-	43	-	4	11	17	30	-	-	-	-	-	-	
	250	12	67	142	-	23	98	2	12	22	32	52	-	-	-	-	8	-	
	400	24	112	232	-	68	188	8	24	40	56	88	-	-	-	12	44	-	
	630	42	180	280	-	136	280	17	42	67	92	143	218	-	-	23	48	98	
	R-630T	-	-	-	-	-	-	42	92	143	193	280	280	-	48	98	149	249	
31,72	160	1,5	24	54	-	-	19	-	1	5	9	17	-	-	-	-	-	-	
	250	6	41	88	-	5	53	-	6	12	19	31	-	-	-	-	-	-	
	400	14	70	145	-	34	110	4	14	24	34	54	-	-	-	-	19	-	
	630	25	113	232	-	78	197	10	25	41	57	90	137	-	-	6	21	54	
	R-630T	-	-	-	-	-	-	25	57	89	121	185	280	-	22	54	85	149	
41,25	160	-	13	31	-	-	3	-	-	2	4	9	-	-	-	-	-	-	
	250	2	23	51	-	-	24	-	2	6	10	17	-	-	-	-	-	-	
	400	7	40	84	-	12	57	1	7	13	19	31	-	-	-	-	3	-	
	630	13	63	130	-	35	102	4	13	22	31	49	75	-	-	3	21	48	
	R-630T	-	-	-	-	-	-	14	32	51	70	108	164	-	5	24	43	81	
50,8	630	9	43	90	-	21	69	2,5	9	15	21	34	53	-	-	-	-	12	
	1000	16	71	146	-	49	124	6	16	26	36	56	86	-	-	4	14	34	
	1500	25	107	218	3	85	196	10	25	40	55	84	129	-	3	18	33	62	
66,7	630	4	24	50	-	6	33	-	4	8	11	18	29	-	-	-	-	11	
	1000	8	40	83	-	22	65	3	8	14	20	31	48	-	-	-	2	14	
	1500	14	61	125	-	44	108	5	14	23	31	48	74	-	-	5	14	30	
88,9	630	1,5	12	28	-	-	15	-	1	3	5	9	16	-	-	-	-	3	
	1000	4	22	46	-	10	34	1	4	7	11	17	27	-	-	-	-	5	
	1500	7	34	70	-	21	58	3	7	12	17	27	41	-	-	-	5	14	
107,92	1000	3	14	30	-	4	20	-	3	5	7	11	18	-	-	-	-	1	
	1500	5	23	47	-	13	37	1	5	8	11	18	28	-	-	-	1	8	
	1500T	11	48	96	1	37	86	5	11	18	24	37	57	-	1	8	14	27	
126,95	1000	1,5	10	22	-	1	13	-	1	3	4	7	12	-	-	-	-	3	
	1500	3	16	34	-	8	25	-	3	6	8	13	20	-	-	-	-	4	
	1500T	8	34	70	-	25	61	3	8	13	17	27	41	-	-	4	9	18	
158,72	1000	0,5	6	13	-	-	6	-	-	1	2	4	7	-	-	-	-	-	
	1500	2	10	21	-	3	14	-	2	3	5	8	12	-	-	-	-	1	
	1500T	5	21	44	-	14	37	2	5	8	10	17	26	-	-	1	4	10	
195	1500	-	7	14	-	-	8	-	1	2	3	5	8	-	-	-	-	2	
	1500T	3	14	29	-	8	23	1	3	5	7	11	17	-	-	-	1	5	
203,2	1500	-	6	13	-	-	7	-	-	2	3	4,5	7	-	-	-	-	2	
	1500T	3	13	27	-	7	21	-	3	4,5	6	10	16	-	-	-	-	5	

Note:

1. In table theoretical acceptable pressure drops are included. Actual pressure drops with consideration of tolerance of spring manufacture and friction of internal parts of the actuator are lower than those given by 20%. Pressure drops chosen that way guarantee internal tightness of closing of the valves.
2. For valves with function "rising control pressure - valve opens" the actuator with springs ranged 40-120 kPa can be replaced with an actuator ranged 40-200 kPa, with the same pressure drops.
3. For reverse-working actuators (type R or R1), supply pressure should be higher than the upper spring range by at least 40kPa.



NOISE REDUCTION

The noise generated out of valve operation caused by cavitations or by aerodynamic effects exceeds the level acceptable by the client, it shall be reduced by means of the following solutions:

- perforated plugs (fig. 1 and tab. 5)
- silencer plates on the valve outlet and/or inside the reduction joint (fig. 3, 4 and tab. 8)
- reduction joints (diffusers) - (fig.4).

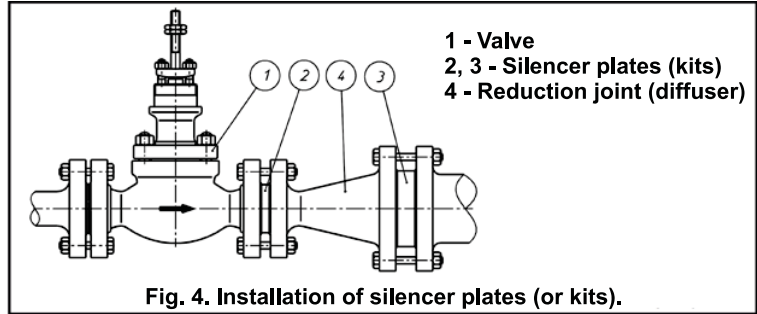
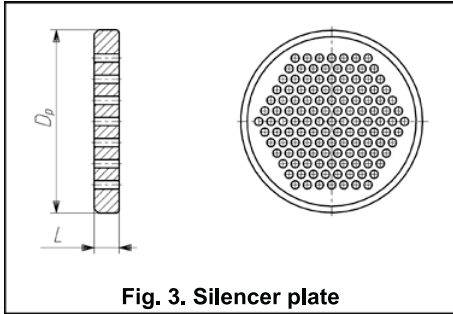

Table 8.: Dimensions and flow ratios of silencing plates.

DN	25	40	50	80	100	150	200	250	300	350
Kvs	10	25	40	94	160	320	500	800	1000	1500
	9	22,5	36	84	144	288	450	720	900	1350
	8	20	32	75	128	256	400	640	800	1200
	7	17,5	28	66	112	224	350	560	700	1050
L [mm]	5	6		10		15		20		
Dp [mm]	68	88	102	138	162	218	285	345	410	465

Multi-plate silence kits are custom-built for requirements of individual processes.

SIZES AND WEIGHTS

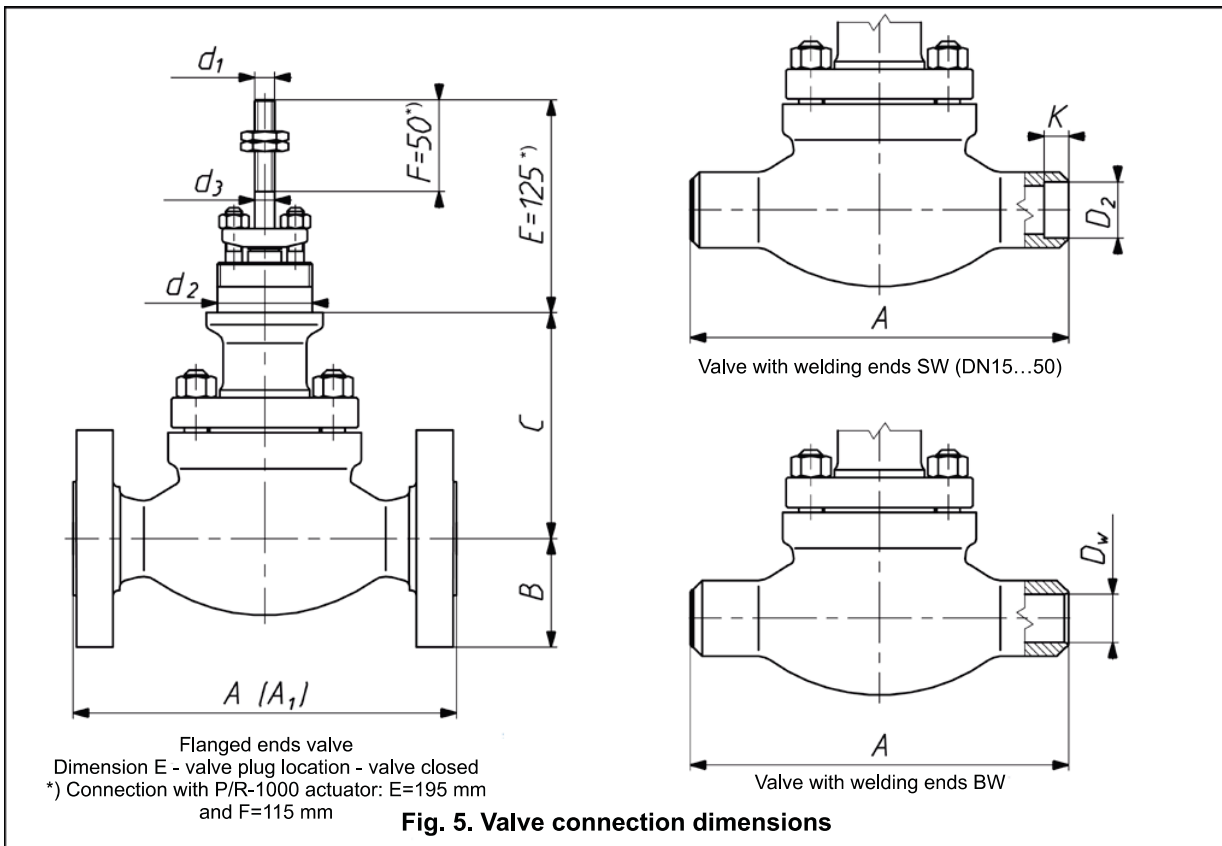



Table 9a.: Connection dimensions of control valves

DN	25						40						50						
PN	PN10... CL300	PN63... CL600	CL900; PN160	PN250; CL1500	PN320	PN400; CL2500	PN10... CL300	PN63... CL600	CL900; PN160	PN250; CL1500	PN320	PN400; CL2500	PN10... CL300	PN63... CL600	CL900; PN160	PN250; CL1500	PN320	PN400; CL2500	
B max	63	70	75		80	90	75	85	93		98	110	83	98	108		105	118	
C	DS	135		149		193		145		172		214		155		175		237	
	DW	306		320		364		306		348		385		326		345		402	
	DM	254	-	-	-	-	254	-	-	-	-	-	270	-	-	-	-	-	-
Weight [kg]	8	8,5		9,5		15,5		17,5		19	20	22	23	22	25	28	31	33	34

DN	80						100						150					
PN	PN10... CL300	PN63... CL600	CL900; PN160	PN250; CL1500	PN320	PN400; CL2500	PN10... CL300	PN63... CL600	CL900; PN160	PN250; CL1500	PN320	PN400; CL2500	PN10... CL300	PN63... CL600	CL900; PN160	PN250; CL1500	PN320	PN400; CL2500
B max	105	145	120	133	138	153	128	138	145	155	168	185	160		178		190	
C	DS	206		233		257		217		252		329		287		365		
	DW	375		402		447		407		442		498		426		483		
	DM	405	-	-	-	-	405	-	-	-	-	-	470		-	-	-	
Weight [kg]	40	43	44	50	51	52	65	72	75	86	89	95	132		147		156	

DN	200			250			
PN	PN10...CL300		PN63...CL600	PN10...CL300		PN63...CL600	
B max	190		235	258		255	
C	DS	439			458		
	DW	539			558		
	DM	580		-	580	660	-
Weight [kg]	195		220	320	330	360	

Note: Weight of valve with standard bonnet and without actuator.

Table 9b.: Connection dimensions of control valves

DN	25..50	50	80	80; 100	80; 100	100	150				200	200; 250			250	
Kvs	10..25	40	25	40	63; 94	125; 160	63; 94	125; 160	200; 250	320	94	125; 160	200; 250	320	500	630; 800
Stroke	20	38	20	38	38	50	38	50	63	80	38	50	63	80	100	
d1	M12x1,25			M16x1,5			M20x1,5			M16x1,5	M20x1,5		M24x1,5			
d2 ¹⁾	57,15 / 2 1/4"-16UN2A						84,15 / 3 5/16"-16NS2A				95,25 / 3 3/4"-12UN2A					
d3	12		16			20						24				
Actuator	160 250 400 630 R-630T	630 R-630T	160 250 400 630 R-630	630 R-630T	630 1000 1500	1000 1500	630 1000 1500	1000 1500	1000 1500 1500T	1500 1500T	1000 1500	1000 1500 1500T	1500 1500T			

Note:

¹⁾ for DN80 and DN100 valves with TA-LUFT packing d2 = 84.15



Table 10.: Construction lengths of control valves with flanged connection

DN	Dimension A [mm]										
	PN / DIN					CL / ANSI					
	10; 16; 25; 40	63 - 100	160	250 - 320	400	CL150	CL300	CL600	CL900	CL1500	CL2500
25	160	230	230	260	300	184	197	210	248	273	308
40	200	260	260	300	350	222	235	251	270	311	359
50	230	300	300	350	400	254	267	286	311	340	400
80	310	380	380	450	500	298	317	336	387	460	498
100	350	430	430	520	580	352	368	394	464	530	575
150	480	550	550	-	-	451	473	508	556	-	-
200	600	650	-	-	-	543	568	610	-	-	-
250	730	775	-	-	-	673	708	752	-	-	-

Note:

Dimensions „A“ as listed in Table 10 for CL150; CL300; CL600; CL900; CL1500; CL2500 apply to bodies with B seat (RF). For other designs dimension A_1 can be calculated using relations presented in Table 11.

Table 11.: Algorithms for calculation of control valve body length for valves with flanged end

- with a groove
- with a key (recess)
- with a groove to the ring

Body type and marking PN / ANSI	Pressure PN / ANSI	DN	A_1
with groove D1/GF	CL300	25...250	$A_1 = A + 5 \times 2$
	CL600 CL900 CL1500 CL2500		$A_1 = A - 1,5 \times 2$
with key (recess) F1/FF	CL300	25	$A_1 = A + 5,5 \times 2$
		25...40	$A_1 = A + 6,5 \times 2$
	CL150	25...250	
	CL300	50...250	$A_1 = A + 8 \times 2$
	CL600 CL900 CL1500	25...40	$A_1 = A$
		CL2500	
	CL600	50...250	$A_1 = A + 1,5 \times 2$
	CL900 CL1500	50...100	
	with ring-joint J / RTJ	CL900	150
CL2500		80	
			100

Table 12.: Construction lengths of control valves with welding ends.

DN	Dimension A [mm]		
	Nominal pressure		
	PN 10...CL600	CL900...PN160	PN250...CL2500
25	210	230	300
40	251	260	350
50	286	300	400
80	337	380	500
100	394	430	580
150	508	550	-
200	610	-	-
250	752	-	-



Table 13.: Butt welding ends BW type PN 10...110

DN	Dz [mm]	t [mm]	Dw [mm]	PN (DIN3239)											
				10	16	25	40	63	100	160	250	320	400		
25	33,7	2,6	28,5	x	x	x	x	x	x						
		2,9	27,9								x				
		3,6	26,5									x			
		5	23,7										x		
		7,1	19,5											x	
		42,4	28,2												x
40	48,3	2,6	43,1	x	x	x	x								
		2,9	42,5					x	x						
		3,6	41,1								x				
		5	38,3									x			
		6,3	35,7										x		
10	28,3											x			
50	28,3	2,9	54,5	x	x	x	x	x							
		3,2	53,9						x						
		4	52,3								x				
		6,3	47,7									x			
		8	44,3										x		
12,5	35,3											x			
80	88,9	3,2	82,5	x	x	x	x								
		3,6	81,7					x							
		4	80,9						x						
		6,3	76,3							x					
		11	66,9								x				
		12,5	63,9									x			
		17,5	53,9										x		
		114,3	79,3											x	
100	114,3	3,6	107,1	x	x	x	x								
		4	106,3					x							
		5	104,3						x						
		8	98,3							x					
		14,2	85,9								x				
		16	82,3									x			
		22,2	69,9										x		
139,7	20	99,7										x			
150	168,3	4,5	159,3	x	x	x	x								
		5,6	157,1					x							
		7,1	154,1						x						
		12,5	143,3							x					
		193,7	168,7								x				
200	219,1	5,9	207,3	x	x										
		6,3	206,5			x	x								
		7,1	204,9					x							
		10	199,1						x						
244,5	12,5	219,5							x						
250	273	6,3	260,4	x	x										
		7,1	258,8			x	x								
		8,8	255,4					x							
	12,5	248						x							

DN	Schedule	Dz [mm]	t [mm]	Dw [mm]	ANSI (ASME 36.10 M)									
					63	100	160	250	320	400				
1"	40	33,4	3,4	26,6	x	x	x	x						
	80		4,5	24,4	x	x	x	x						
	160		6,4	20,6						x				
	XXS		9,1	15,2								x		
2"	40	60,3	3,9	52,5	x	x	x	x						
	80		5,5	49,3						x				
	160		8,7	42,9							x			
XXS	11,1	38,1									x			
4"	40	114,3	6	102,3	x	x	x							
	80		8,6	97,1						x				
	120		11,1	92,1								x		
	160		13,5	87,3									x	
	XXS		17,1	80,1										x
6"	40	168,3	7,1	154,1	x	x								
	80		11	146,3			x	x						
	120		14,3	139,7					x					
	160		18,3	131,7						x				
8"	20	219,1	6,4	206,3	x	x								
	30		7	205,1			x							
	40		8,2	202,7				x						
	60		10,3	198,5					x					
	80		12,7	193,7						x				
10"	20	273	6,4	260,2	x	x								
	30		7,8	257,4			x							
	40		9,3	254,4				x						
	60		12,7	247,6					x					
80	15,1	242,8						x						

Where:

Dz [mm] - pipe external diameter

Dw [mm] - pipe internal diameter

t [mm] - pipe wall thickness

NOTE:

•) - execution with reduction stubs - discuss with technical dep't POLNA Corp.

Table 14. Socket welding ends, SW type.

DN	D ₂	K
25	34	13
40	48,7	
50	61	16

**VALVE ACTUATOR**

• **Pneumatic** – diaphragm multi-spring actuator as per Table 15 type:

- P1/R1 – with cast yoke, no handwheel
- P1B/R1B – with cast yoke, side-mounted handwheel
- P/R – column type, no handwheel
- PN/RN – column type, top-mounted handwheel

Note: P – direct action; air-to-close
R – reverse action; air-to-open

Table 15. Pneumatic actuator types.

Type	Size	Diaphragm effective area [cm ²]	Stroke [mm]	Number of manual actuator turns for full stroke
P/R ; PN/RN	160	160	20	5
	250	250		
P1/R1 ; P/R ; P1B/R1B ; PN/RN	400	400	20 ; 38	5 ; 9
	630	630		
	R-630T *)	2 x 630		
P1/R1 ; P1B/R1B	1000	1000	38 ; 50 ; 63	8 ; 10 ; 13
	1500	1500	38 ; 50 ; 63 ; 80 ; 100	8 ; 10 ; 13 ; 16 ; 20
	1500T	2 x 1500		

*) - there is no top mounted handwheel for R-630T

Table 16. Dimensions and weight of pneumatic actuators P/R and PN/RN - fig. 6

Actuator size	D ₁ [mm]	D ₂ [mm]	H ₁ [mm]	H ₂ [mm]	Weight [kg]	
					P/R	PN/RN
160	210	225	306	468	9	13,5
250	240		324	486	10	14,5
400	305		332	494	16	20,5
630	375	305	424	586	30	37
R-630T		-	638	-	45	-
1000	477	450	607	847	74	100
1500	550	-	704	-	95	-
1500T		-	1008	-	200	-

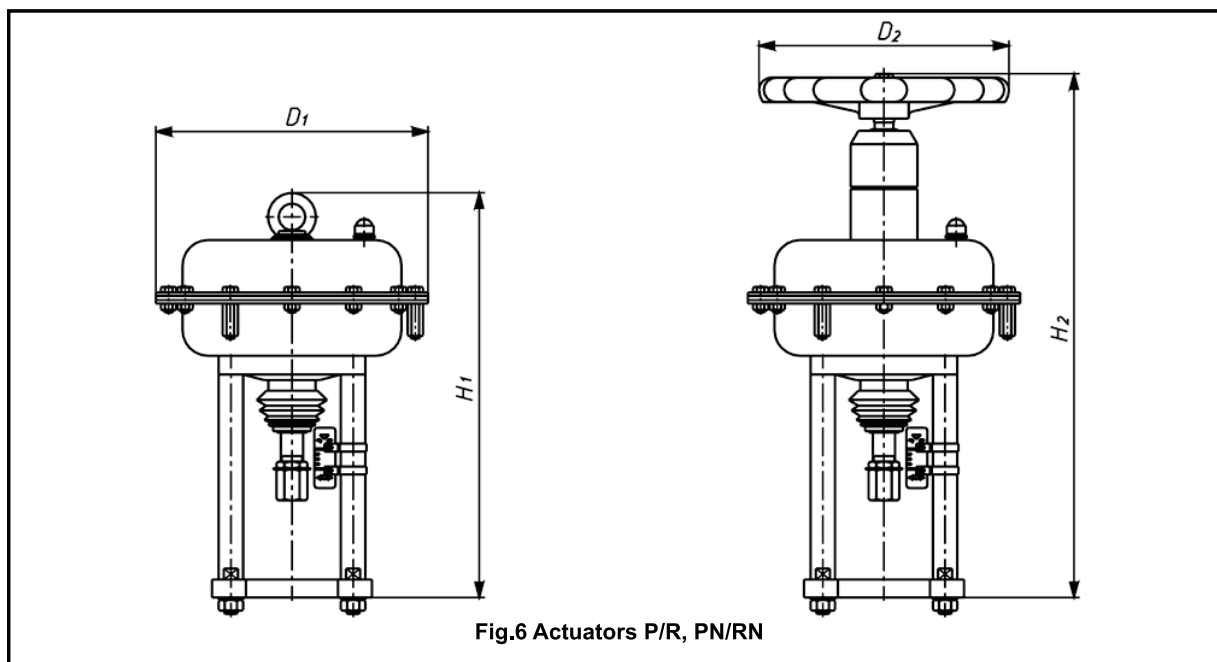
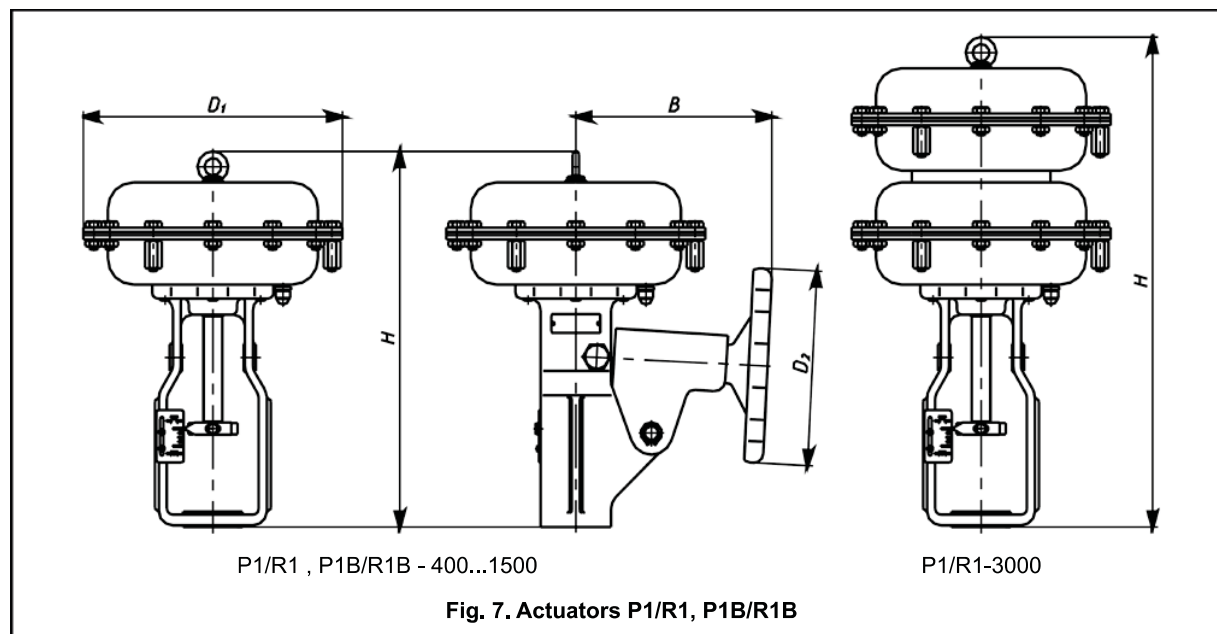

Table 17. Sizes and weights of pneumatic actuators P1/R1 and P1B/R1B - Fig. 7

Actuator size	B [mm]	D ₁ [mm]	D ₂ [mm]	H [mm]	Weight [kg]	
					P1/R1	P1B/R1B
400	255	305	225	453	20	28
630	280	375	305	548	40	50
1000	340	477	450	773	85	105
1500	410	550		833	120	150
1500T				1138	225	255

**Technical specification of pneumatic actuators**

- control air connections: 1/4" NPT ; Rc 1/2"
- tube diameters: 6x1 ; 8x1 ; 12x1
- spring ranges:

20...100 kPa; 40...120 kPa; 60...140 kPa	- 3 springs
40...200 kPa; 80...240 kPa; 120...280 kPa	- 6 springs
180...380 kPa	- 12 springs

 (not applicable for actuators P/R; P1/R1 - 250; 400)

Note: For actuator P1/R1-3000 (Tandem) – for each range double the above numbers of springs.

- maximum supply pressure: actuator size 160...630 - 600 kPa
actuator size R-630T a 1000...1500T - 500 kPa

Accessories (optional):

- manual drive side-mounted (P1/R1) or top-mounted (P/R)
- pneumatic positioner
- electropneumatic positioner
- smart electropneumatic positioner
- pressure air filter-reductor
- 3/2-way solenoid valve
- lock-up valve
- position transmitter
- limit switches

• **Electric actuators** – electrically operated actuators; electrohydraulic, domestic; imported (detailed technical information - as per the catalogue cards of the actuator manufacturers).

• **Manual drives** – manual drive, type 20, fig.8, tab.18.

**Table 18. Types, dimensions and weight of manual drive type 20.**

Type	Stroke	d_1	d_2	H	D	No of turns for full stroke	Weight [kg]	
20-20-57-M12	20	M12x1,25	57,15	265	228	8	7,5	
20-20-84-M12			84,15					
20-38-57-M12			57,15					
20-38-57-M16	38	M16x1,5	84,15		298	15	10	
20-38-84-M16			95,25					
20-38-95-M16			57,15					
20-50-57-M16	50	M16x1,5	84,15	385	457	16	16	
20-50-84-M16			95,25					
20-50-95-M16			84,15					
20-63-84-M20	63	M20x1,5	95,25		533	610	19	24
20-63-95-M20			84,15					
20-80-84-M20			95,25					
20-80-95-M20	80							
20-100-95-M24	100	M24x1,5						

Marking:

Example: 20-38-57-M16 – Manual drive type 20; stroke - 38mm; $d_2=57,15$ mm; $d_1=M16x1,5$

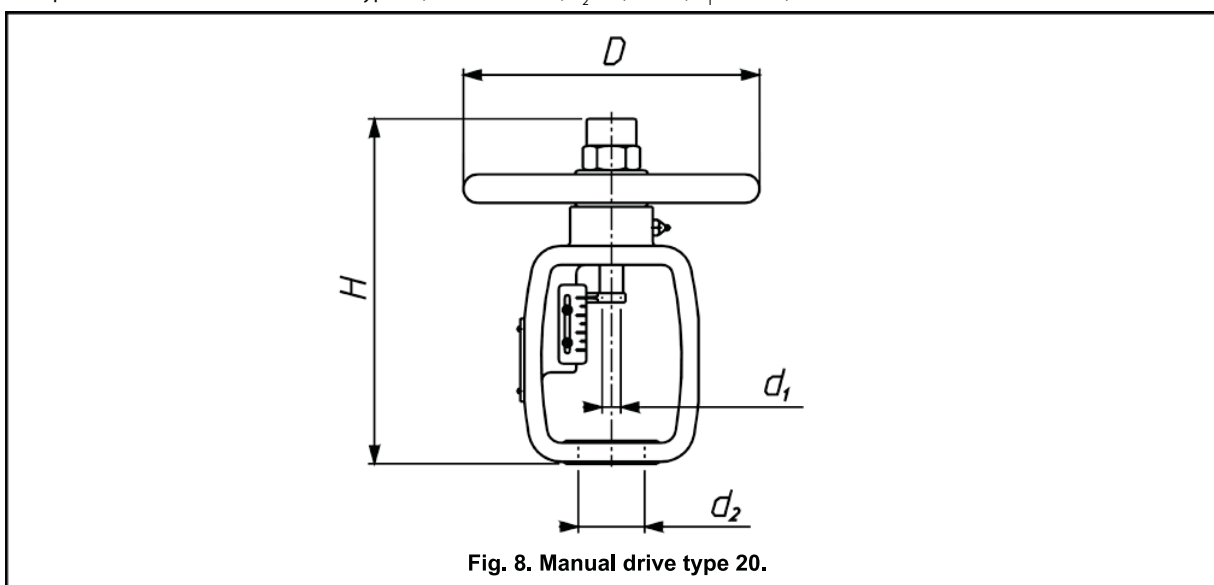
**SPECIAL OPTIONS**

- **valves for oxygen and hydrogen:**

Application of adequate materials, mechanical and chemical cleaning, inspections and assembly ensure compatibility with oxygen and hydrogen flows.

- **valves for liquid and gaseous fuels with high speed travel:**

Driven by pneumatic actuators with quick closing systems - valve closing time-below 1 sec.

- **valves for cryogenic service:**

Proper materials and special design of the seal to prevent the valve drive from being affected by low temperatures. Used mainly for liquid oxygen and nitrogen.

- **valves for acid gases:**

Parts of valve can be made of materials and under conditions to enable valve operation with gases of H₂S content as per NACE MR-0175.

- **valves with a heating jacket:**

Design and technical parameters-as agreed with the client individually.

- **balanced valves with pilot:**

Construction allows achievement of high leakage class at high pressure drops and reduced available force of actuator, flow direction - above the plug.

- **valves with non-cast bodies:**

If a special construction of the valve body is needed, it is possible to design a valve for individual customer's needs (angle valves – type L and Z)



MARKING:

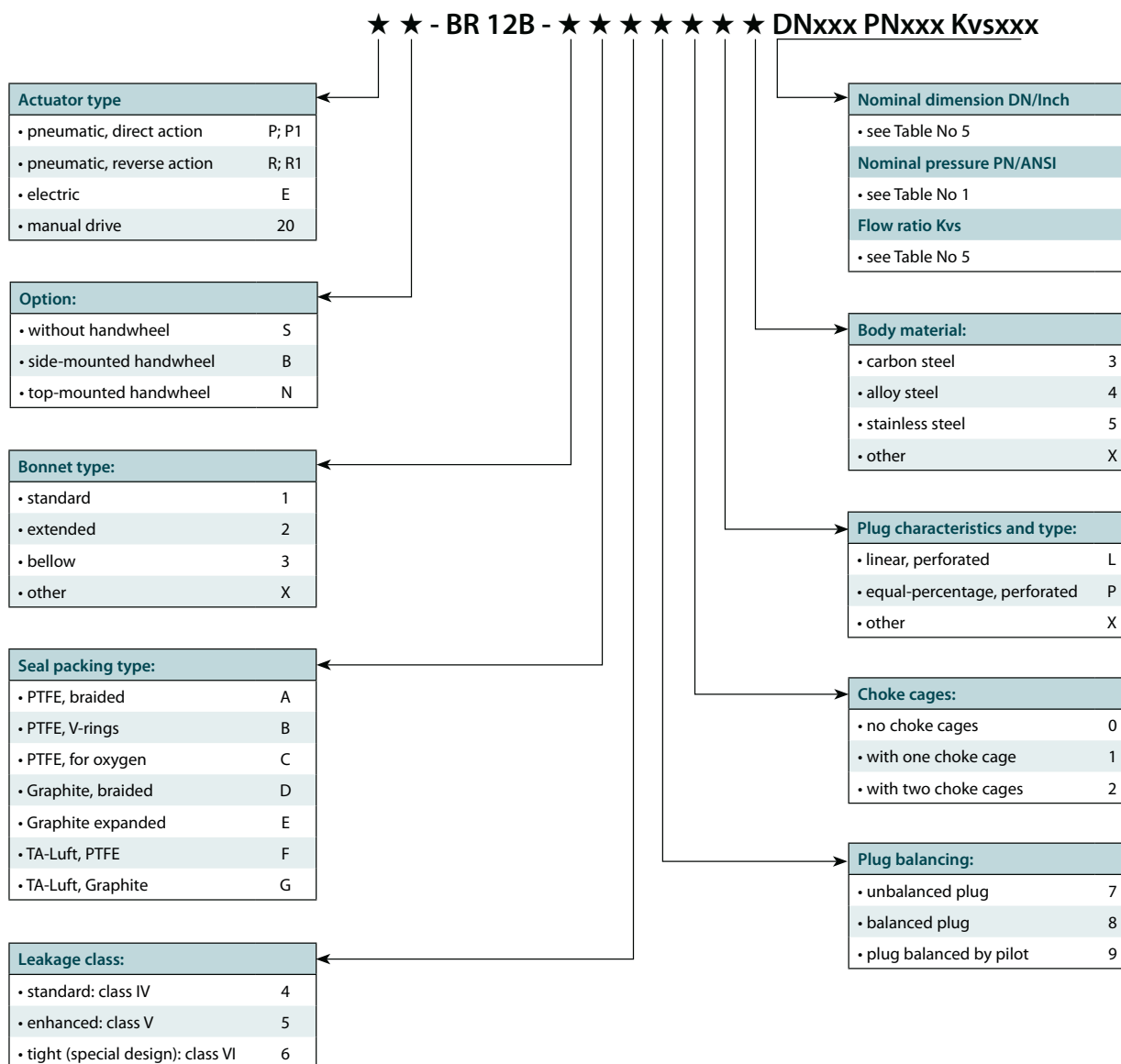

MARKING EXAMPLE:

Control valve series BR 12B with pneumatic actuator (reverse action) with manual drive, extended bonnet. Seal packing by expanded Graphite, leakage class IV, with one choke cage, equal-percentage plug. Body material alloy steel:

RN-BR 12B-2E481P4 DN80 PN250 Kvs63

Valve can be equipped by choke cages: 1, 2 or none - depending on construction allowance of DN and Kvs and based on needs related to valve calculations.

Such marking is shown on valve nameplate..

On the nameplate additionally mentioned:

- maximum working temperature [TS]
- maximum working pressure [PS]
- test pressure [PT]
- plug stroke [H]
- fluid group [1 or 2]
- serial number and year of manufacture







Sesto Valves, LLC

Head office:

114 Resource Drive
Wentzville, MO 63385
tel.: +1 636 856 8576



FLOCONX[™]
— USA FLOW CONTROL COMPANY —

**FLOCONX LLC
USA FLOW CONTROL COMPANY**

**SALES | INFORMATION
SALES@FLOCONX.COM
VENTAS@FLOCONX.COM**

FLOW CONTROL, OUR PASSION.™

WWW.FLOCONX.COM