

# Masoneilan\* **28000** Series Varipak Control Valves

Precise Microflow Valves  
with Compact Design  
and Flexible Capabilities.



# Table of Contents

Numbering System.....	2	Varilog Anti-Cavitation Varipak.....	9
Micro-flow Control Innovation.....	3	High Pressure Varipak.....	10
General Data.....	4	Bellows Seal Varipak.....	11
Materials of Construction.....	5-6	Cryogenic Varipak.....	12
Standard Flangeless Varipak.....	7	Accessories and Options.....	13
Standard Flanged Varipak.....	8	Standard Actuator Options.....	14

## Numbering System

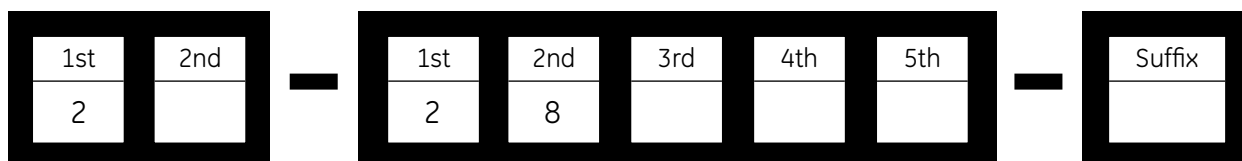

Actuator Type		Body Series	Actuator Mounting Position (Refer to Figure 2)	Trim N°	Max. C <sub>v</sub>	Adjustable C <sub>v</sub>	Construction Option
27	Air-to-Close	28	0 Undefined	0	3.8	0 Undefined 1 Without 2 With	Standard
28	Air-to-Open		1 (*) (**)	1	2.3		A Angle
			2 (**)	2	1.2		BS Bellows seal
			3	3	0.6		EB Cryogenic
			4	4	0.25		HP High pressure
			* Standard actuator mounting arrangement	5	0.10		MS Anti-cavitation
			** Flanged valve mounting position Face-to-face = 102 mm (4.02")	6	0.050		SP Special
				7	0.025		
				8	0.010		
				9	0.004		

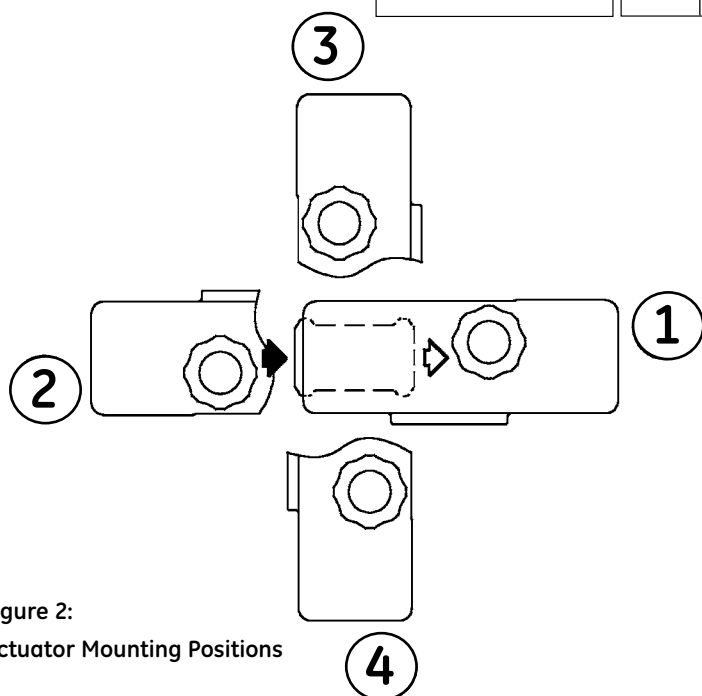

Figure 2:  
Actuator Mounting Positions

# Microflow Control Innovation

## Optimized $C_v$ Characteristics

The VariPak valve outshines conventional microflow valves with its support of a wide range of nominal  $C_v$  values (from 0.0016 to 3.8), using only eight plugs and five seats.

## Precise $C_v$ Calibration and Selection - $C_v$ and $F_L$

Valve Sizes			Trim No.	Flow Coefficient $C_v$									Critical Flow Factor $F_L$
.5" (15mm)	.75" (20mm)	1" (25mm)		With Adjustable $C_v$ Function							Without Adjustable $C_v$ Function		
				Min.		Risk-Free <sup>(3)</sup>		Max.					
•	•	•	9	0.0016	0.0020	0.0024	0.0028	0.0032	0.0036	<b>0.0040</b>	<b>0.0040</b>	0.85	
•	•	•	8	0.004	0.005	0.006	0.007	0.008	0.009	<b>0.010</b>	<b>0.010</b>	0.85	
•	•	•	7	0.010	0.013	0.016	0.019	0.021	0.023	<b>0.025</b>	<b>0.025</b>	0.85	
•	•	•	6	0.020	0.025	0.030	0.035	0.040	0.045	<b>0.050</b>	<b>0.050</b>	0.85	
•	•	•	5	0.04	0.05	0.06	0.07	0.08	0.09	<b>0.10</b>	<b>0.10</b>	0.85	
•	•	•	4	0.10	0.13	0.16	0.19	0.21	0.23	<b>0.25</b>	<b>0.25</b>	0.90	
•	•	•	3	0.25	0.30	0.35	0.40	0.45	0.50	0.55	<b>0.60</b>	<b>0.60</b>	0.90
•	•	•	2	0.5	0.6	0.7	0.8	0.9	1.0	1.1	<b>1.2</b>	<b>1.2</b>	0.92
•	•	•	1	0.9	1.1	1.3	1.5	1.7	1.9	2.1	<b>2.3</b>	<b>2.3</b>	0.92
	•(2)	•(1)	0	1.5	1.9	2.3	2.6	2.9	3.2	3.5	<b>3.8</b>	<b>3.8</b>	0.92

(1) Flangeless, flanged or threaded connections.

(2) Flangeless or threaded connections.

(3) The "Risk-free" setting allows for easy valve capacity adjustments in the field to meet changing service conditions.



Figure 3: Flow Coefficient Adjustment

# General Data

## Body

Type:	globe style angle style optional
Sizes:	1" (DN 25) standard 1/2" (DN 15) and 3/4" (DN 20) optional
Materials:	Standard: type 316L St. St. Optional: Monel®, Hastelloy® C, Alloy 20, others
Options:	Flanged valve Anti-cavitation Varilog High pressure Bellows seal Cryogenic Angle valve NACE version

## Trim

Plug type:	contoured, heavy top guided multi-staged anti-cavitation (Varilog)
optional	
Seat type:	metal seat
C <sub>v</sub> ratio:	500/1 at max. C <sub>v</sub> 200/1 at min. C <sub>v</sub>
Flow characteristics:	linear (trim No. 0 to 5) modified linear (trim No. 6 to 9)
Flow Direction:	flow-to-open flow-to-close optional

## Actuator

Type:	spring-opposed rolling diaphragm
Action:	direct or reverse, easily performed without additional parts
C <sub>v</sub> adjustment:	optional adjustable knob/lever
Handwheel:	optional top mounted
Air connection:	1/8" NPT

## Temperature Range/Seat Leakage

Valve Type	Temperature Range <sup>(1)</sup>	Seat Class <sup>(2)</sup>	
Standard and High Pressure Valves	-320°F to +650°F (-196°C to +343°C)	IV	V
Cryogenic Valves	-320°F to +300°F (-196°C to +150°C)		
Varilog Anti-Cavitation Valves	-20°F to +650°F (-29°C to +343°C)		

<sup>(1)</sup> Please consult GE for applications outside the temperature ranges noted.

<sup>(2)</sup> Class IV seat leakage is standard and Class V is optional. Seat leakage class ratings per IEC 534-4 and ANSI/FCI 70-2.

## Rating/End Connections<sup>(3)</sup>

Valve Sizes		Maximum C <sub>v</sub>	ASME Class 150-1500 ISO PN 20-250					ASME Class 150-600 ISO PN 20-100	
inches	mm		Flangeless	Threaded	SW	BW	Flanged Face-to-Face: 6.3" (160mm)	Flanged Face-to-Face: 4" (102mm)	
.5	15	2.3	•	•	•		•	•	
.75	20	2.3	•	•	•		•	•	
1	25	3.8	•	•	•	•	•	•	

<sup>(3)</sup> Please consult GE for applications requiring ASME Class 2500/ISO PN 420 rating.

# Materials of Construction

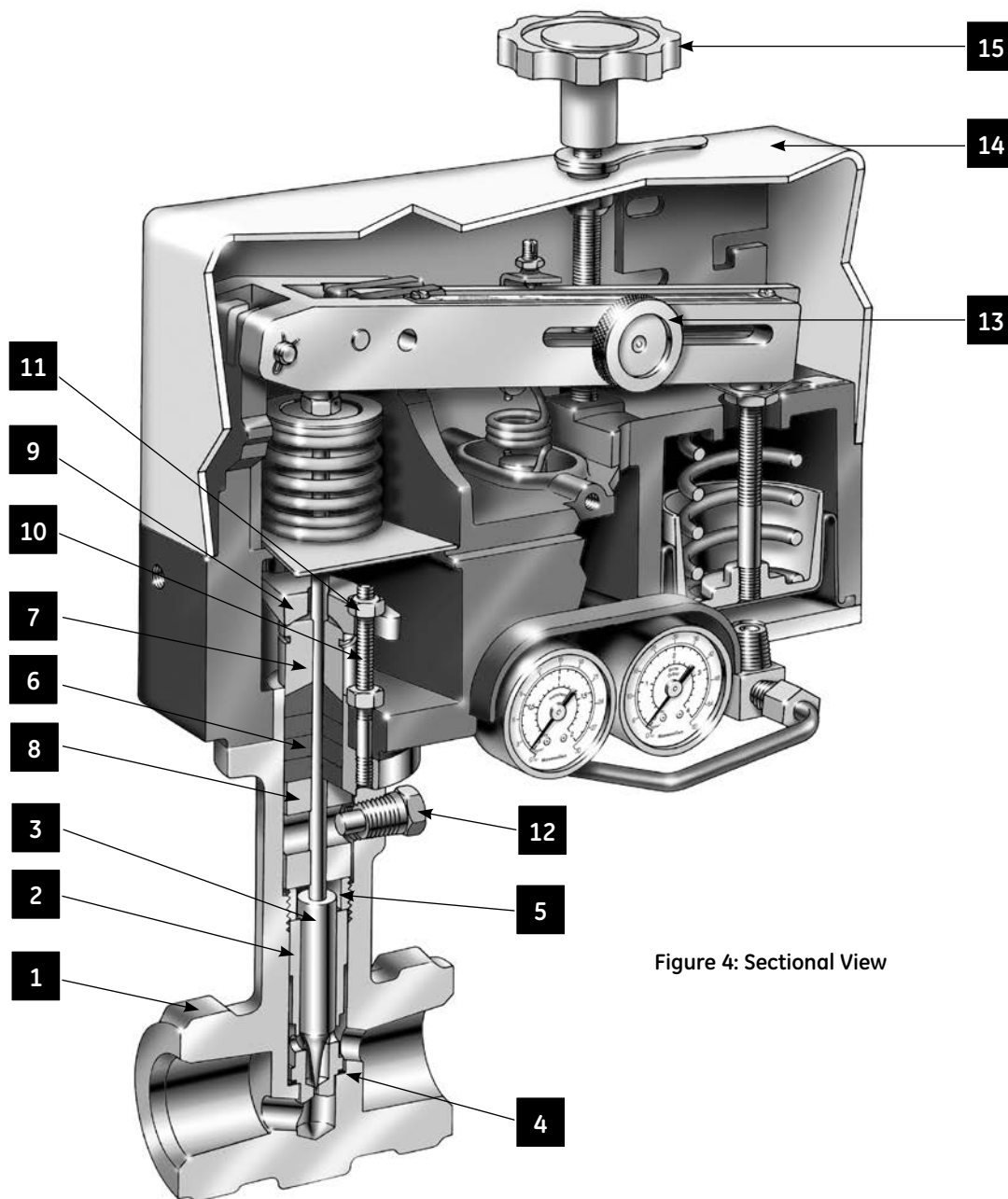

Figure 4: Sectional View

# Materials of Construction

## Materials<sup>(5)</sup> (Standard and NACE Construction)<sup>(1)</sup>

Ref. No.	Temperature Range	-320°F -196°C	+650°F +343°C	-20°F -29°C	+450°F +232°C
		Standard Materials (Optional Materials)		NACE Materials	
1	Body	316L St. St. ASTM A182 Gr. F 316L (forging)		316L St. St. ASTM A182 Gr. F 316L (22 HRC Max.)	
		316L St. St. ASTM A351 Gr. CF3M (casting)		316L St. St. ASTM A351 Gr. CF3M (22 HRC Max.)	
		<i>Optional: Monel®, Hastelloy® C, Alloy 20</i>			
2	Seat	17-4 PH St. St. ASTM A564 Gr. 630 Condition H900 (Max C <sub>V</sub> ≥ 0.10, trims No. 0 to 5)		MONEL K 500 (35 HRC Max.)	
		Solid Stellite No. 6 or Equivalent (Max C <sub>V</sub> ≤ 0.05, trims No. 6 to 9)		Solid Stellite No. 6 or Equivalent	
		<i>Optional: 440C St. St. Monel®, Hastelloy® C, Alloy 20</i>			
3	Plug and Stem S/A	Plug Solid Stellite No. 6 or Equivalent (Max C <sub>V</sub> ≥ 0.10, trims No. 0 to 5)		Plug Solid Stellite No. 6 or Equivalent	
		Stem 316 St. St. (Max C <sub>V</sub> ≥ 0.10, trims No. 0 to 5)		Stem 316 St. St. (22 HRC Max.)	
		One part Solid Stellite No. 12 or Equivalent (Max C <sub>V</sub> ≤ 0.05, trims No. 6 to 9)		One part Solid Stellite No. 12 or Equivalent	
		<i>Optional: 440C St. St., Monel®, Hastelloy® C, Alloy 20</i>			
4	Seat Ring Gasket	316 St. St. with Flexible Graphite Filler (Spiral Wound) with 316 St. St. inserts			
5	Seat Ring Retainer	17-4 PH St. St. ASTM A564 Gr. 630 Condition H1075		MONEL K 500 (35 HRC Max.)	
6	Packing	Carbon Core bridged PTFE (standard up to ASME Class 1500)			
		Lattyflon® (with optional Viton® O-rings)		Lattyflon® (with optional Viton® O-rings)	
7	Packing Follower	303 St. St. ASTM A582 TY 303		ASTM A479 TY 304 (22 HRC Max.)	
8	Packing Spacer	316 St. St. ASTM A479 TY 316		316L St. St. (22 HRC Max.)	
9	Packing Flange	304 St. St. AISI 304		304 St. St. (22 HRC Max.)	
10	Packing Flange Studs	304 St. St. ASTM A193 Gr. B8 (Standard up to ASME Class 1500)		304 St. St. ASTM A193 Gr. B8 (Class I) exposed and non-exposed (Standard up to ASME Class 1500)	
11	Packing Flange Nuts	304 St. St. ASTM A194 Gr. 8		304 St. St. ASTM A194 Gr. 8 Non-exposed 304 St. St. ASTM A194 Gr. 8A Exposed (22 HRC Max.)	
12	Safety Pin <sup>(6)</sup>	316 St. St. ASTM A479 TY 316		316 St. St. (22 HRC Max.)	
13	C <sub>V</sub> Adjustment Knob	Stainless Steel		Stainless Steel	
14	Actuator Cover	Polycarbonate		Polycarbonate	
		<i>Optional: Stainless Steel</i>		<i>Optional: Stainless Steel</i>	
15	Handwheel (optional)	Lexan® + Austenitic St. St.		Lexan® + Austenitic St. St.	

(1) Materials and processes in accordance with the requirements of NACE specification MR0103.

Applications requiring compliance to MR0175, 2003 Rev. or ISO 15156 would require engineering review.

(2) Materials designated for these parts conform to NACE Class III bolting requirements.

(3) Materials designated for these parts conform to NACE Class I or Class II bolting requirements.

(4) Consult GE for NACE Applications above ASME Class 600 rating.

(5) Materials noted throughout this text are for reference only. GE reserves the right to supply trade name material or equivalent.

(6) Not applicable for 28000 HP.

Material not applicable

# Standard Flangeless Varipak

## 28000 Series

Due to its simple, compact, and versatile stainless-steel body design, the standard flangeless Varipak valve is widely used across a variety of industries.

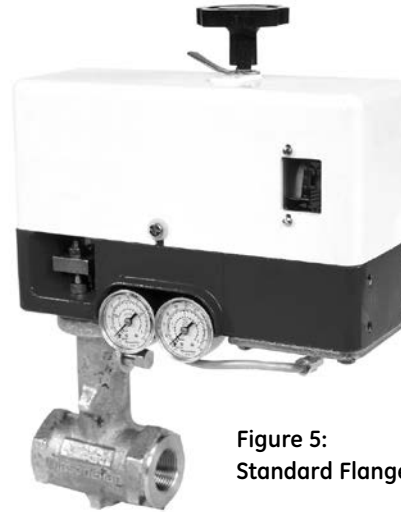

Figure 5:  
Standard Flangeless Varipak

## Rated $C_v$ Range/Weight

Body/Actuator Assembly Weight	Rated $C_v$ Range
15.4 lbs (7 kg)	3.8 to 0.0040 (trim No. 0 to 9)

## Dimensions – inches (mm)

Standard Varipak (Stainless Steel)

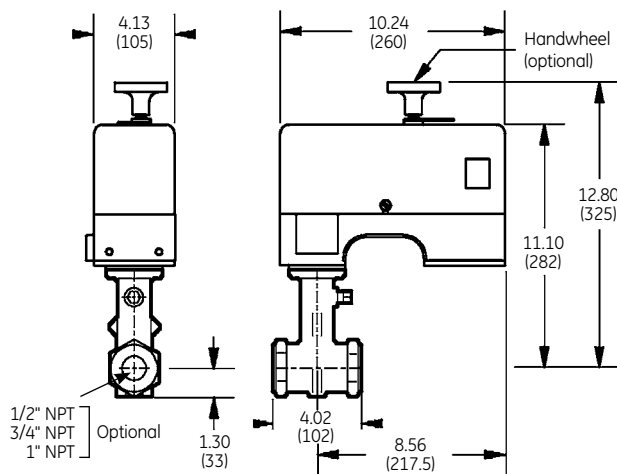

Provide a removal clearance of 5.5 inches (140 mm)

Bar Stock Body

(For Non-Castable Material)

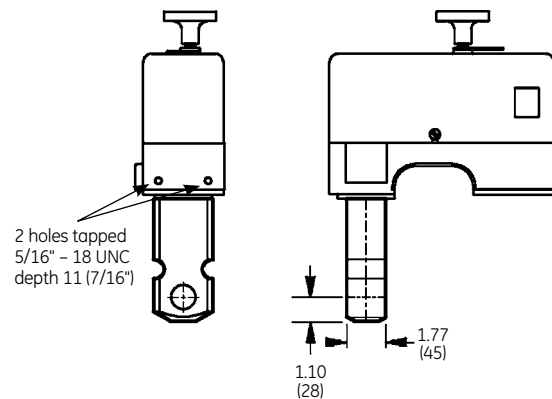

# Standard Flanged Varipak

## 28000 Series

The Varipak is also available in flanged configurations with connections and ratings as indicated in the following table.

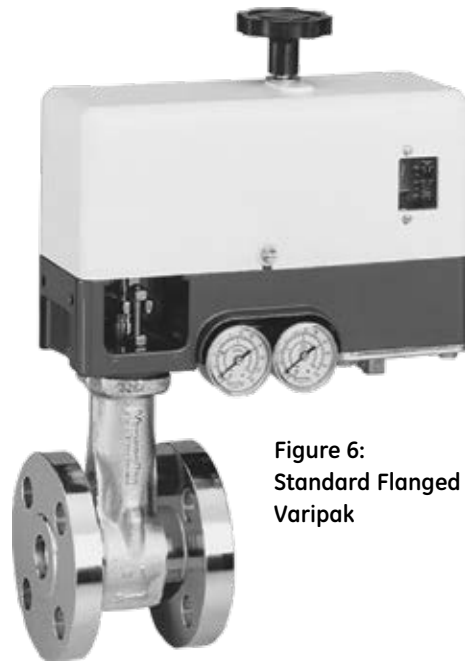

Figure 6:  
Standard Flanged  
Varipak

## Flange Ratings/Weight

Face-to-Face Dimensions	Flange Ratings	Body/Actuator S/A Weight <sup>(1)</sup>	Rated C <sub>v</sub> Range
4" (102mm)	ASME Class 150-600 ISO PN 20-100 (raised face only)	8 to 10 kg (17.4 to 22 lbs)	3.8 to 0.0040 (trim No. 0 to 9)
6.3" (160mm)	ASME Class 150-1500 ISO PN 20-250 DIN PN 10-250 (RF, FF, RTS, etc...)	10 to 12 kg (22 to 26.5 lbs)	

<sup>(1)</sup> depending on rating.

## Dimensions – inches (mm)

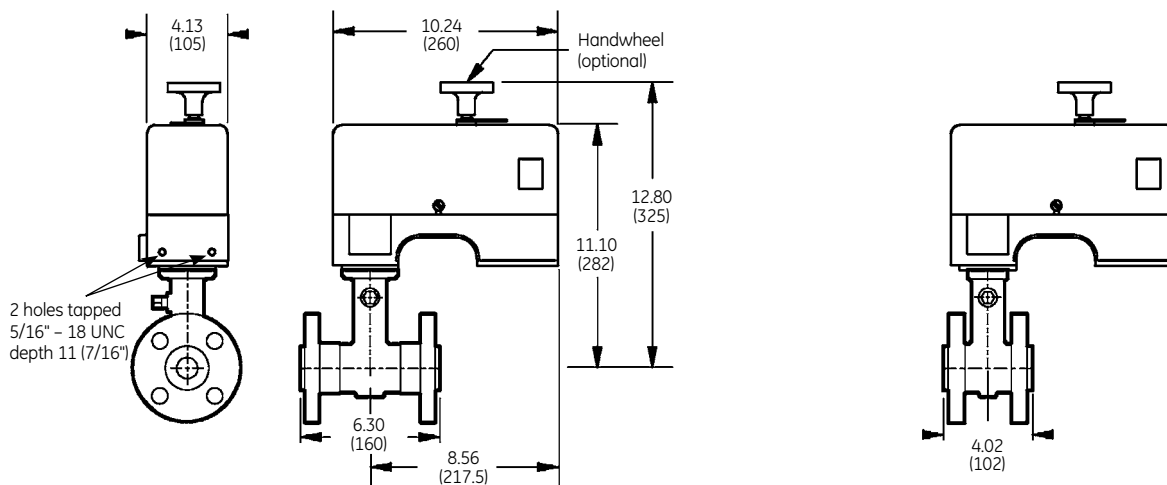

Provide a removal clearance of 5.5 inches (140 mm)



# Varilog\* Anti-Cavitation Varipak



## 28000 MS Series

The Varilog multi-stage trim design for the Varipak control valve provides unmatched anti-cavitation performance in low flow applications.

By reducing erosion and vibrations, this design helps minimize failure that is often associated with conventional single-seated valves. The Varilog trim is available with the standard Varipak body designs in either the flanged or flangeless configurations.

Figure 7: Varilog Trim Subassembly

## Specific Characteristics

Rated $C_v$ Range	Critical Flow Factor $F_L$	Temperature Range	Materials	
0.60 to 0.050 (trim No. 3 to 6)	0.98	-20°F to +660°F (-29°C to +350°C)	Seat	ASTM A 564 Gr. 630 Condition H900 Type 17-4 PH St. St.
			Plug and Stem S/A	One part from solid Stellite No. 12 or Equivalent or ASTM A 276 type 440 C St. St.
			Other Parts	Standard Construction: see page 6

## Dimensions – inches (mm)

Standard Varipak (Stainless Steel)

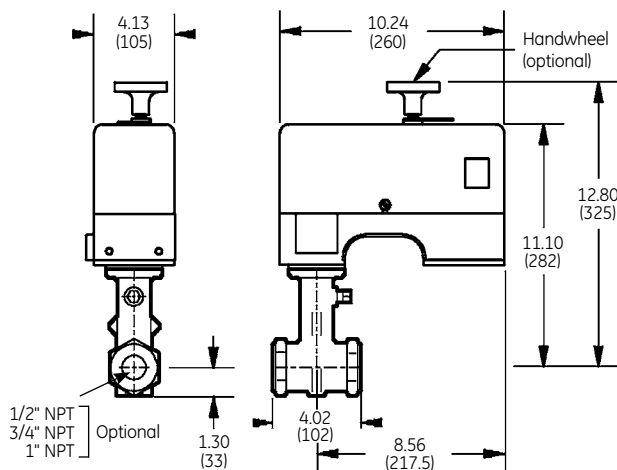

Provide a removal clearance of 5.5 inches (140 mm)

Bar Stock Body  
(For Non-Castable Material)

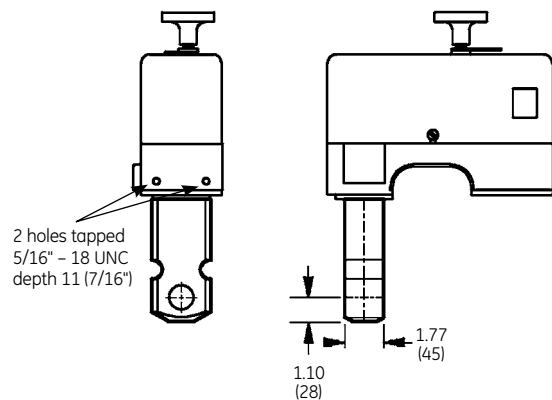

# High Pressure Varipak

## 28000 HP Series

The high-pressure Varipak valve design is recommended for applications involving conditions with very high upstream pressure or pressure drop that exceeds the pressure rating of the standard Varipak body design.

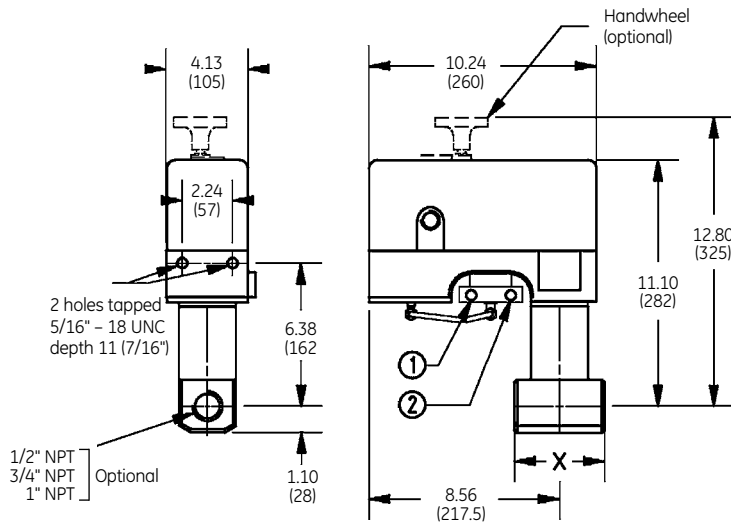

**Figure 8:**  
High Pressure Varipak

### Specific Characteristics

Rated C <sub>v</sub> Range	Body Rating	Seat Leakage	Materials	
0.60 to 0.0040 (trim No. 3 to 9)	ASME Class 2500 ISO PN 420	Class IV	Body	ASME A 182 Gr. F 316L Optional: ASTM A182 Gr. F 316
			Other Parts	Standard Construction: see page 6

### Dimensions – inches (mm)



Provide a removal clearance of 5.5 inches (140 mm)

Valve Sizes		X	
inches	mm	inches	mm
.5	15	3.15	80
.75	20	4.02	102
1	25		

# Bellows Seal Varipak

## 28000 BS Series

For applications that require no leakage at the packing box, the Varipak valve is available with a bellows seal. This design is ideal for applications that involve the handling of flammable, toxic, or explosive fluids.

Figure 9A:  
Bellows Seal Varipak

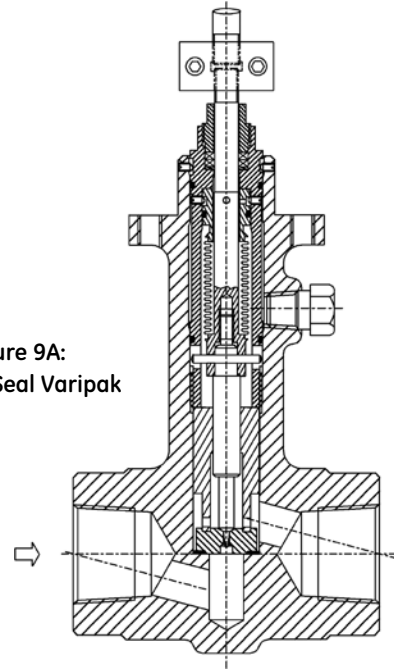

## Specific Characteristics

Rated $C_v$ Range	Body Rating	Seat Leakage	Operating Pressures	Materials	
2.3 to 0.0040 (trim No. 1 to 9)	ASME Class 150-600 ISO PN 10-100	Class IV	800 psi at +212°F (55 bar at +100°C)  580 psi at +392°F (40 bar at +200°C)	Body	ASTM A 182 Gr. F 316L Optional: A182 Gr. F 316
				Plug/Bellows Subassembly	Plug and Seat: Standard Materials Bellows Assembly: 316L St. St. Viton® O-rings
				Other Parts	Standard Construction: see page 6

## Dimensions – inches (mm)

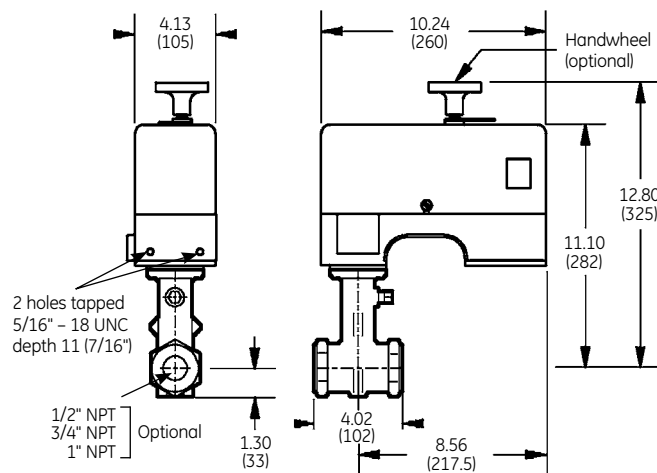

Provide a removal clearance of 5.5 inches (140 mm)



Figure 9B:  
Plug and Bellows Subassembly

# Cryogenic Varipak

## 28000 EB Series

### Simplified maintenance

This Varipak control valve design meets the requirements of cryogenic processes that require thermal insulation. An insulating interface sets up between the valve body (cold zone) and the body extension located in the higher temperature area (warm zone). The valve body assembly and its thermal extension are positioned inside the cold box, and the plug can easily be removed and inspected without disturbing the valve body. This eliminates the need for any preliminary, complicated dismounting, and more importantly, prevents any interference with the cold box.

### Body

Manufactured from a material suitable for low temperatures, the valve body maintains ductility in service. It can be conveniently mounted to suit specific piping needs, as long as the angle between the valve axis and vertical does not exceed 60°.

The bonnet is located away from the cryogenic fluid, which means that the body gasket is not inside the cold zone. This design prevents any leakage of the cryogen into the insulated zone.

### Body extension

To reduce the inflow of heat by conduction, thin-walled metal tubes are used for the body extension and coupling sleeve. In addition, the annular space is reduced to exclude convection currents.

### Plug

The design of the plug allows the working parts to be accurately centered in relation to the seat and provides a uniform temperature zone for the guiding.

## Specific Characteristics

Rated C <sub>v</sub> Range	Temperature Range	Body Rating	Seat Leakage	Materials	
3.8 to 0.10 (trim No. 0 to 5)	-320°F to +300°F (-196°C to +150°C)	ASME Class 150-600 ISO PN 20-100 excepted trim No. 0: ASME Class 150-300 ISO PN 20-50	Class IV	Body and Extension	ASTM A 182 Gr. F 316L
				Plug/Stem	Standard Material
				Seat	Trim No. 0: Standard Material Trim No. 1 to 5: ASTM A 564 Gr. 630 Condition H900 Type 17-4 PH. St. St.
				O-ring Seat Gasket	PTFE
				Other Parts	Standard Construction: see page 6

## Dimensions – inches (mm)

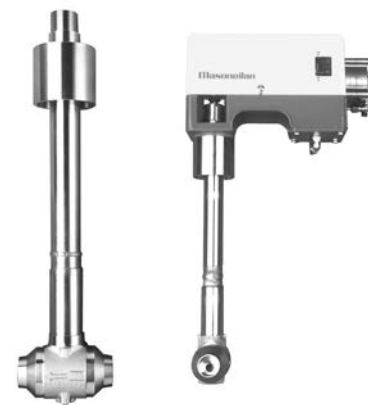
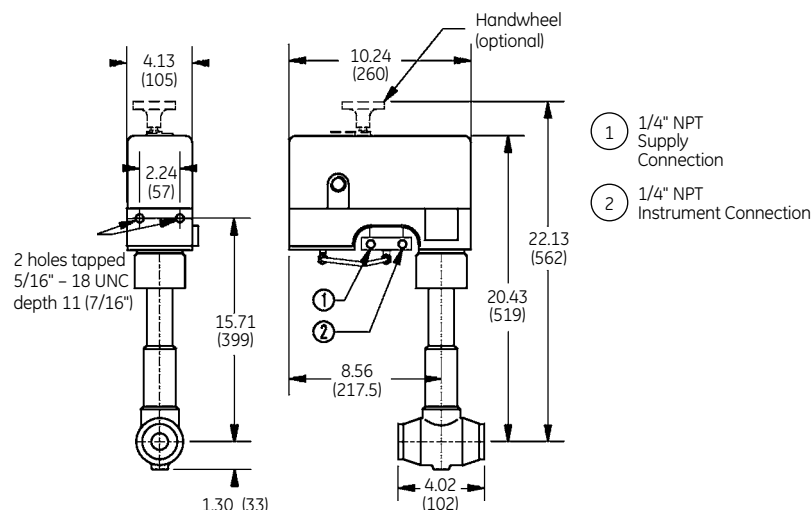
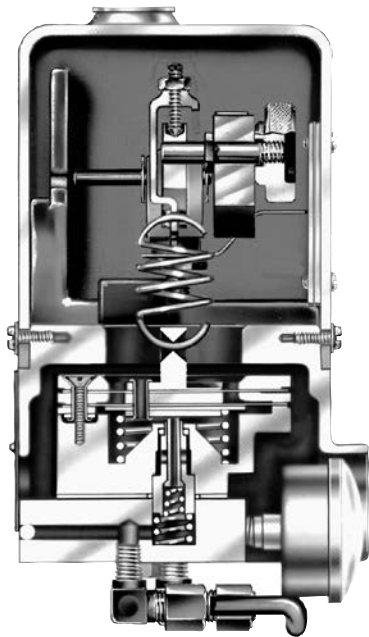

Figure 10: Cryogenic Varipak

Provide a removal clearance of 5.5 inches (140 mm)

# Accessories and Options



**Figure 11: Model 7700P Pneumatic Positioner**

## Pneumatic Positioner (Model 7700P)

Type	pneumatic, force balance	Supply pressure effect	0.05 percent of full stroke variation per psi supply pressure change (0.07 percent per 100 mbar)
Mounting	built-in bracket in actuator	Open loop gain	70
Action	direct: increasing instrument signal increases air output	Linearity	± 0.5 percent
Characteristics	linear	Sensitivity	0.1 percent
Instrument signal	3 to 15, 6 to 30 or 3 to 27 psi 200 to 1000, 400 to 2050 or (200 to 1850 mbar) 3 to 9, and 9 to 15 psi (200 to 600 and 600 to 1000 mbar) split range	Repeatability	0.1 percent
Connections	1/4" NPT instrument and supply - 1/8" NPT output	Full stroke time	less than one second
Average air consumption	0.15 scfm at 30 psi supply (0.26 Nm <sup>3</sup> /h at 2.1 bar supply)	Weight	3.3 lbs (1.5 kg)
Max. air output	4.20 scfm (7 Nm <sup>3</sup> /h)	<b>Other Accessories</b>	Proximity sensors and limit switches Digital positioners - HART® and Fieldbus Foundation Handwheel, airsets and solenoid valves

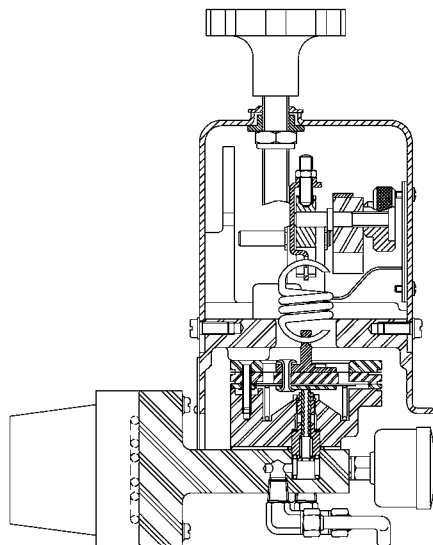

**Figure 12: Model 7700E Electropneumatic Positioner**

## Electropneumatic Positioner (Model 7700E)

Type	electropneumatic, force balance	<b>Hazardous Location Protection</b>
Mounting	compact, without external linkage to the actuator (see Fig. 15)	ATEX Approvals (2014/34/EU Directive)
Action	direct: increasing instrument signal increases air output	Explosionproof No. SIRA 02 ATEX 1274 Intrinsic Safety No. SIRA 02 ATEX 2277 X
Characteristics	linear	FM (Factory Mutual) Approvals
Instrument signal	4-20 mA	Explosionproof Intrinsic Safety Non-incendive and Dust-ignitionproof
Air Connections	1/4" NPT supply - 1/8" NPT output	CSA Approvals (Canadian Standards Association)
Average air consumption	0.24 scfm (0.4 Nm <sup>3</sup> /h)	Explosionproof Intrinsic Safety Non-incendive
Electrical connections	1/2" NPT or M20	CUTR Approvals (Custom Union Technical Regulation)
Weight	7.7 lbs (3.5 kg)	Explosionproof Intrinsic Safety

# Standard Actuator Options

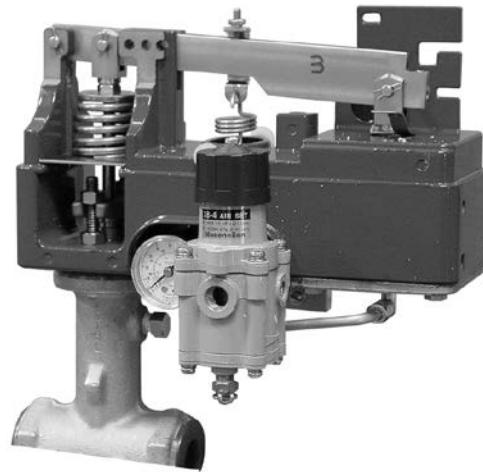
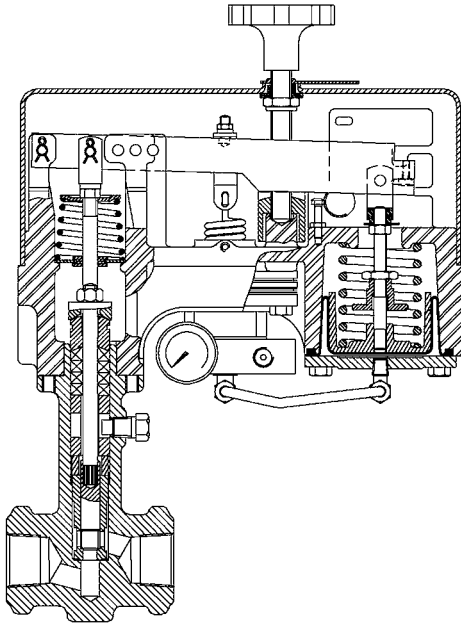

Figure 14: Varipak with Non-Adjustable  $C_v$  Actuator (cover removed)

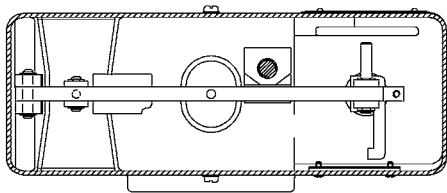

Figure 13: Non-Adjustable  $C_v$  Actuator



Figure 15: Varipak with 7700E Electropneumatic Positioner

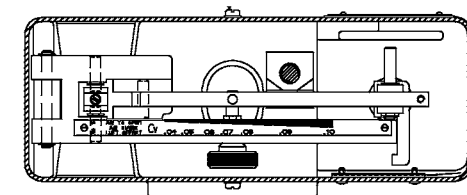
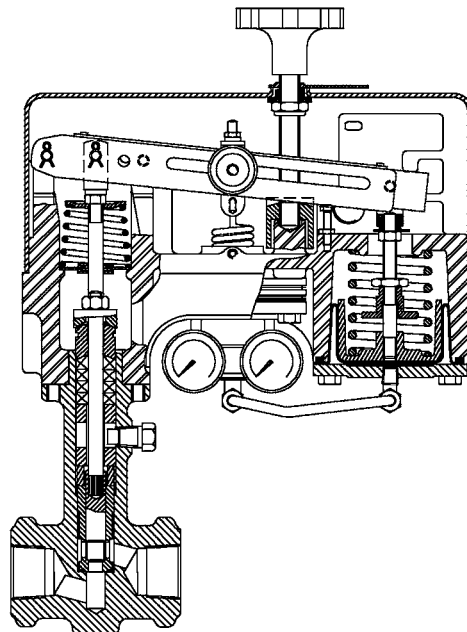

Figure 16: Adjustable  $C_v$  Actuator



**FLOCONX LLC**  
**USA FLOW CONTROL COMPANY**

**SALES | INFORMATION**  
**SALES@FLOCONX.COM**  
**VENTAS@FLOCONX.COM**

**FLOW CONTROL, OUR PASSION.™**

**WWW.FLOCONX.COM**