

Masoneilan* 21000 Series

Complete Line of Rugged,
Top Guided, Globe Valves with
Lo-dB* and Anti-Cavitation
Capabilities

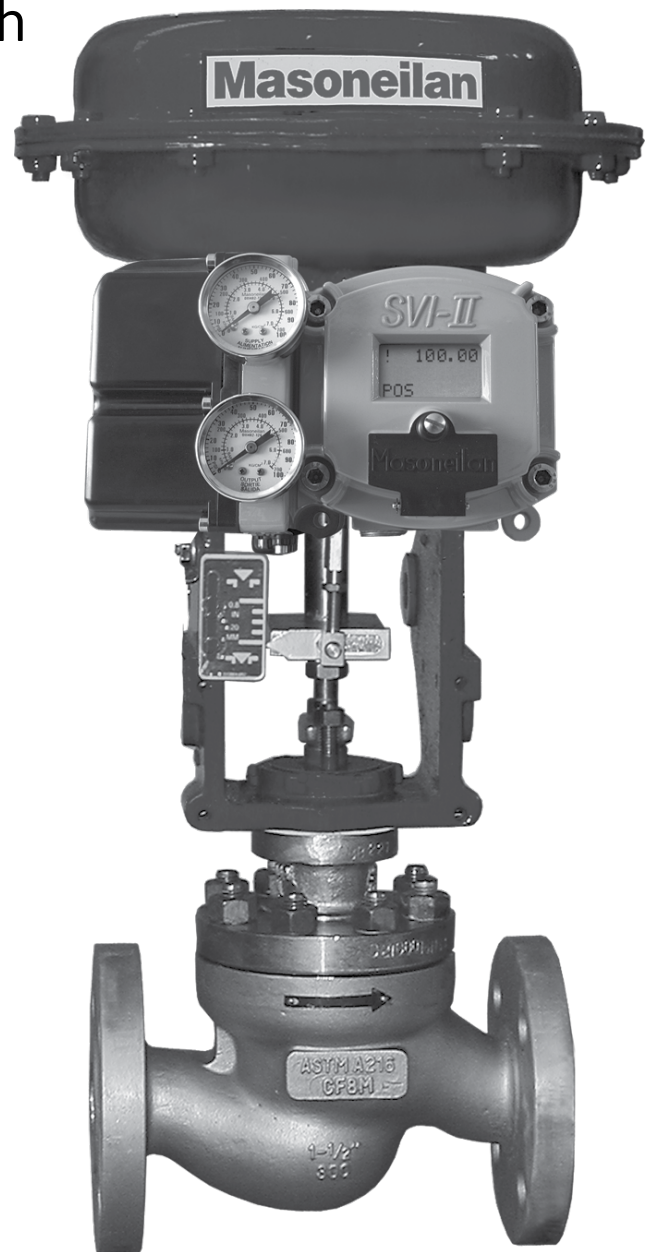

Table of Contents

Numbering System3

Ratings/Connections(1)5

Cv and FL versus Travel.....6-16

Materials of Construction 17-22

Bellows Seal Design Features 21000 BS Series.....23

Materials of Construction24-26

Dimensions (inches)27-28

Dimensions (mm)29-30

Weights.....31

Dimensions and Weights (in./lbs)32

Dimensions and Weights (mm/kg)33

Numbering System

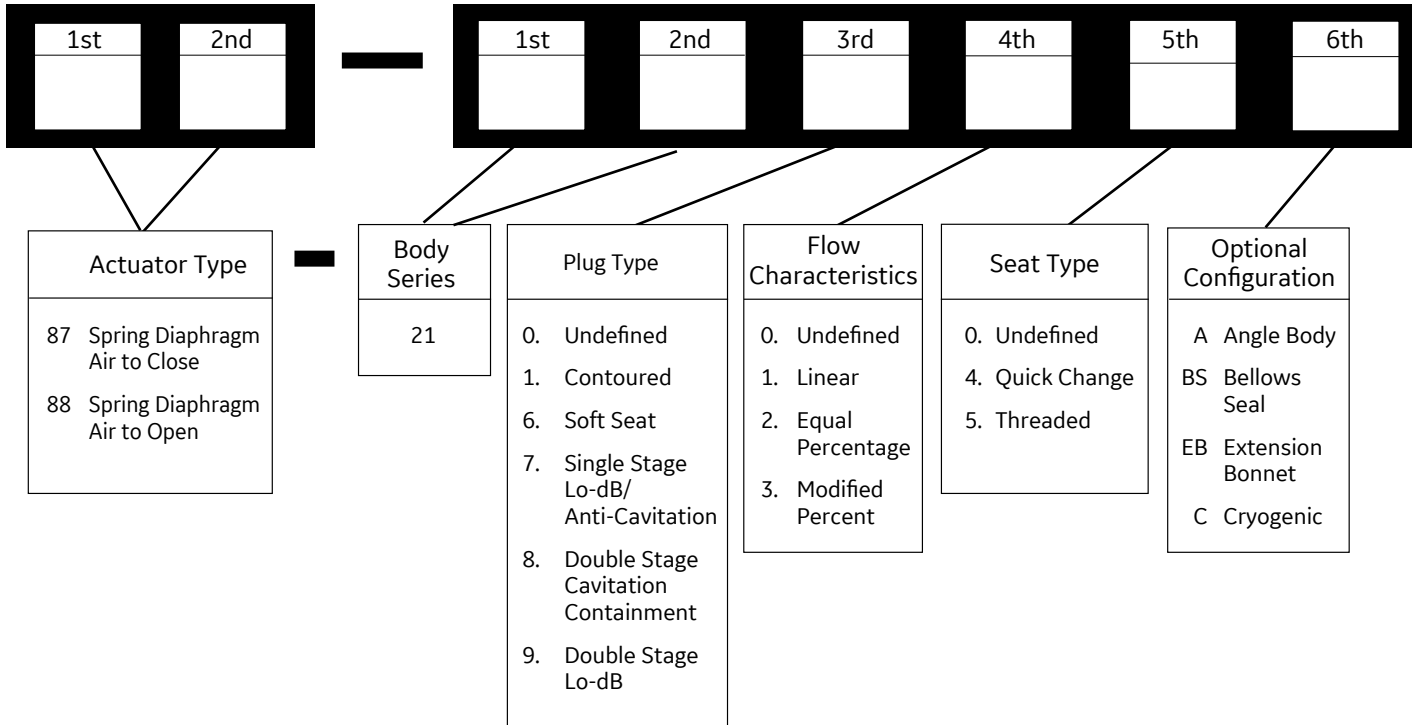

Temperature Range/Seat Leakage

Contoured Trim

Valve Size		Body ⁽¹⁾ Rating	Seat Type	Packing Material	Temperature Range ⁽²⁾				Cryogenic Extension		Seat Leakage IEC 60534-4 and ANSI/FCI 70.2		
Inch	mm				Standard Bonnet		Extension Bonnet		min.	max.	min.	max.	Class
					min.	max.	min.	max.					
0.75 to 8	20 to 200	ASME Class 150 to 2500 and equivalent PN	Metal	PTFE, LE* or LE FireSafe Packing	-20°F (-29°C)	+450°F (+232°C)	-50°F (-46°C)	+800°F (+427°C)			IV	V	
				Graphite Packing	-20°F (-29°C)	+800°F (+427°C)	-50°F (-46°C)	+800°F (+427°C)					
				V-ring					-320°F (-196°C)	-20°F (-29°C)			
			Soft Seat ⁽⁶⁾	Any	-20°F (-29°C)	+450°F (+232°C)	-50°F (-46°C)	+450°F (+232°C)			VI		

Lo-dB*/Anti-Cavitation Trim (1 or 2 Stage Design)³

Valve Size		Body ⁽¹⁾ Rating	Seat Type	Packing Material	Temperature Range ⁽²⁾				Cryogenic Extension		Seat Leakage IEC 60534-4 and ANSI/FCI 70.2		
Inch	mm				Standard Bonnet		Extension Bonnet		min.	max.	min.	max.	Class
					min.	max.	min.	max.					
0.75 to 8	20 to 200	ASME Class 150 to 2500 and equivalent PN	Metal	PTFE, LE* or LE FireSafe Packing	-20°F (-29°C)	+450°F (+232°C)	-50°F (-46°C)	+800°F (+427°C)			IV	V	
				Graphite Packing	-20°F (-29°C)	+800°F (+427°C)	-50°F (-46°C)	+800°F (+427°C)					
				V-ring					-320°F (-196°C)	-20°F (-29°C)			

- ASME Class 900-1500 available only in 0.75 to 4 inch (20 to 100 mm) sizes.
ASME Class 2500 available only in 0.75 to 2 inch (20 to 50 mm) sizes.
- See Materials of Construction Tables for other temperature limitations.
- 2-Stage design only available with Quick Change seat rings.
- 2-Stage Anti-Cavitation Trim not available in 6 inch (150 mm) and 8 inch (200 mm) size.
- LE* Packing for low emissions applications is limited to maximum pressure and temperature as shown in the chart below.
- Soft seat is limited to a maximum of 1000 psi (70 bar) shut-off and a maximum of 450°F (232°C).

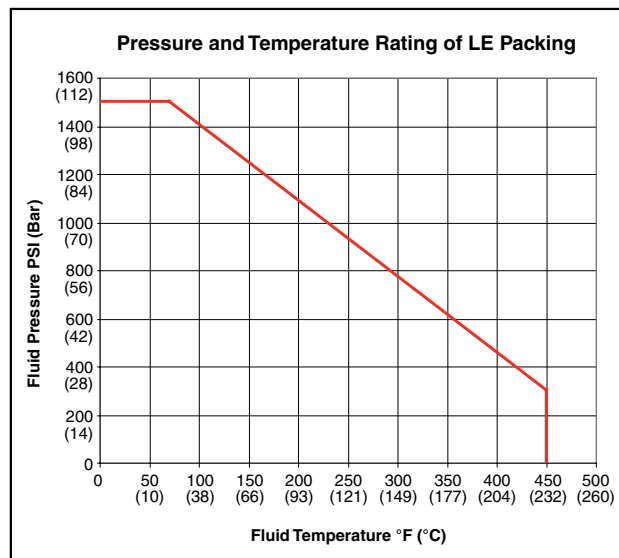

Ratings/Connections⁽¹⁾

Valve Size		ASME Class 150 (PN 20)					ASME Class 300 (PN 50)					ASME Class 600 (PN 100)				
Inch	mm	RF	SW	THD	RTJ	BW	RF	SW	THD	RTJ	BW	RF	SW	THD	RTJ	BW
0.75	20	X	X	X			X	X	X	X		X	X	X	X	
1	25	X	X	X			X	X	X	X		X	X	X	X	
1.5	40	X	X	X			X	X	X	X		X	X	X	X	
2	50	X	X	X		X	X	X	X	X	X	X	X	X	X	X
3	80	X				X	X			X	X	X			X	X
4	100	X				X	X			X	X	X			X	X
6	150	X				X	X			X	X	X			X	X
8	200	X				X	X			X	X	X			X	X

Valve Size		ASME Class 900 (PN 150)					ASME Class 1500 (PN 250)					ASME Class 2500 (PN 420)				
Inch	mm	RF	SW	THD	RTJ	BW	RF	SW	THD	RTJ	BW	RF	SW	THD	RTJ	BW
0.75	20	X	X		X		X	X		X		X	X		X	
1	25	X	X		X		X	X		X		X	X		X	
1.5	40	X	X		X		X	X		X		X	X		X	
2	50	X	X		X	X	X	X		X	X	X	X		X	X
3	80	X			X	X	X			X	X					
4	100	X			X	X	X			X	X					

1) Standard flange of Ra 125-250. Other flange facings and surface finishes available.

C_v and F_L versus Travel

Contoured Trim

Direction: FLOW-TO-OPEN (FTO)
Flow Characteristic: LINEAR

Percent of Travel							10	20	30	40	50	60	70	80	90	100		
F _L							0.93	0.93	0.92	0.92	0.91	0.91	0.91	0.9	0.9	0.9	0.9	
Valve Size		ASME Rating	Orifice Diameter		Travel		Rated C _v											
Inch	mm		Inch	mm	Inch	mm												
Close clearance 0.75 and 1 ⁽¹⁾	Close clearance 20 and 25	150-600	0.125	3.2	0.8	20.3	0.01	0.02	0.03	0.04	0.05	0.06	0.07	0.08	0.09	0.1		
			0.25	6.4	0.8	20.3	0.02	0.04	0.06	0.07	0.09	0.11	0.13	0.15	0.18	0.2		
			0.25	6.4	0.8	20.3	0.03	0.06	0.08	0.11	0.13	0.16	0.19	0.23	0.27	0.3		
			0.25	6.4	0.8	20.3	0.04	0.08	0.11	0.14	0.18	0.22	0.26	0.3	0.36	0.4		
			0.25	6.4	0.8	20.3	0.06	0.12	0.17	0.22	0.27	0.32	0.38	0.45	0.54	0.6		
			0.25	6.4	0.8	20.3	0.08	0.16	0.22	0.29	0.36	0.43	0.51	0.6	0.72	0.8		
			0.25	6.4	0.8	20.3	0.1	0.2	0.28	0.36	0.45	0.54	0.64	0.76	0.9	1		
0.75	20	150-1500	0.25	6.4	0.8	20.3	0.15	0.31	0.46	0.61	0.77	0.94	1.12	1.31	1.50	1.7		
			0.375	9.5	0.8	20.3	0.34	0.68	1.02	1.36	1.72	2.11	2.51	2.93	3.36	3.80		
			0.5	12.7	0.8	20.3	0.54	1.07	1.60	2.15	2.72	3.33	3.96	4.62	5.30	6		
			0.812	20.6	0.8	20.3	1.09	2.15	3.21	4.30	5.45	6.65	7.92	9.24	10.60	12		
1	25	150-1500	0.25	6.4	0.8	20.3	0.15	0.31	0.46	0.61	0.77	0.94	1.12	1.31	1.50	1.7		
			0.375	9.5	0.8	20.3	0.34	0.68	1.02	1.36	1.73	2.11	2.51	2.93	3.36	3.8		
			0.5	12.7	0.8	20.3	0.54	1.08	1.61	2.15	2.72	3.33	4.0	4.63	5.31	6		
			0.812	20.6	0.8	20.3	1.09	2.16	3.22	4.31	5.45	6.66	7.93	9.25	10.6	12		
1.5	40	150-1500	0.25	6.4	0.8	20.3	0.15	0.31	0.46	0.61	0.77	0.94	1.12	1.31	1.50	1.7		
			0.375	9.5	0.8	20.3	0.34	0.68	1.02	1.36	1.73	2.11	2.51	2.93	3.36	3.8		
			0.5	12.7	0.8	20.3	0.54	1.08	1.61	2.15	2.72	3.33	4.0	4.63	5.31	6		
			0.812	20.6	0.8	20.3	1.18	2.33	3.48	4.66	5.9	7.2	8.58	10	11.5	13		
			0.994	25.2	0.8	20.3	2.11	4.18	6.06	7.91	9.89	11.67	13.65	15.39	16.65	18		
			1.25	31.8	0.8	20.3	2.27	4.49	6.7	8.97	11.3	13.9	16.5	19.3	22.1	25		
2	50	150-1500	0.25	6.4	0.8	20.3	0.15	0.31	0.46	0.61	0.77	0.94	1.12	1.31	1.50	1.7		
			0.375	9.5	0.8	20.3	0.34	0.68	1.02	1.36	1.73	2.11	2.51	2.93	3.36	3.8		
			0.5	12.7	0.8	20.3	0.54	1.08	1.61	2.15	2.72	3.33	4.0	4.63	5.31	6		
			0.812	20.6	0.8	20.3	1.36	2.7	4.02	5.38	6.81	8.32	9.91	11.6	13.3	15		
			0.994	25.2	0.8	20.3	2.22	4.41	6.4	8.35	10.44	12.32	14.4	16.25	17.58	19		
			1.25	31.8	0.8	20.3	2.36	4.67	6.97	9.33	11.8	14.4	17.2	20.1	23	26		
			1.625	41.3	0.8	20.3	4.17	8.27	12.3	16.5	20.9	25.5	30.4	35.5	40.7	46		
3	80	150-1500	0.994	25.2	1.5	38.1	2.34	4.65	6.74	8.79	11.0	12.97	15.16	17.1	18.5	20		
			1.25	31.8	1.5	38.1	2.81	5.57	8.31	11.1	14.1	17.2	20.5	23.9	27.4	31		
			1.625	41.3	1.5	38.1	4.26	8.45	12.6	16.9	21.3	26.1	31.1	36.2	41.6	47		
			2.000	50.8	1.5	38.1	8.43	16.7	24.26	31.65	39.57	46.68	54.58	61.57	66.6	72		
			2.625	66.7	1.5	38.1	9.97	19.8	29.5	39.5	49.9	61	72.7	84.8	97.3	110		
4	100	150-1500	0.994	25.2	1.5	38.1	2.34	4.65	6.74	8.79	11.0	12.97	15.16	17.1	18.5	20		
			1.625	41.3	1.5	38.1	4.44	8.81	13.1	17.6	22.3	27.2	32.4	37.8	43.3	49		
			2.000	50.8	1.5	38.1	8.67	17.2	24.93	32.53	40.67	47.97	56.1	63.28	68.45	74		
			2.625	66.7	1.5	38.1	10.3	20.3	30.3	40.6	51.3	62.7	74.7	87.1	99.9	113		
			3.5	88.9	1.5	38.1	17.7	35.1	52.3	70	88.6	108	129	150	172	195		
6	150	150-600	2.000	50.8	2	50.8	9.5	18.8	27.3	35.6	44.5	52.5	61.4	69.3	74.9	81		
			2.625	66.7	2	50.8	11.4	22.7	33.8	45.2	57.2	69.9	83.2	97.2	111	126		
			3.5	88.9	2	50.8	18.9	37.4	55.7	74.6	94.5	115	137	160	184	208		
			4.375	111	2	50.8	35.13	69.7	101	131.9	164.9	194.5	227.4	256.5	277.5	300		
			5	127	2	50.8	36.3	71.9	107	143	182	222	264	308	354	400		
8	200	150-600	3.5	88.9	2	50.8	20	40	60	80	101	124	148	172	197	224		
			4.375	111	2	50.8	37	74	108	141	176	207	243	274	296	320		
			5	127	2	50.8	37	75	112	148	187	230	274	319	365	415		
			6.25	158.7	2.5	63.5	57	115	173	228	289	355	422	493	563	640		

Standard Bellows Seal construction available for ASME Class 150 - 300 (PN 20 - PN 50) and capacities of C_v = 1.7 and higher.

1. Close clearance 0.75 and 1 are available in quick change trim only (Model 21114).
2. Models 21614 and 21615 available only in Cv ranges as indicated by gray background.

C_v and F_L versus Travel

Contoured Trim

Direction: FLOW-TO-OPEN (FTO)
Flow Characteristic: EQUAL PERCENTAGE

Percent of Travel							10	20	30	40	50	60	70	80	90	100		
F _L							0.93	0.93	0.93	0.93	0.93	0.92	0.92	0.91	0.91	0.91		
Valve Size		ASME Rating	Orifice Diameter		Travel		Rated C _v											
			Inch	mm	Inch	mm												
Inch	mm																	
0.75	20	150 - 1500	0.25	6.4	0.8	20.3	0.05	0.08	0.11	0.18	0.3	0.5	0.8	1.1	1.5	1.7		
			0.375	9.5	0.8	20.3	0.12	0.17	0.24	0.39	0.68	1.13	1.76	2.5	3.26	3.8		
			0.5	12.7	0.8	20.3	0.18	0.27	0.38	0.62	1.07	1.79	2.77	3.95	5.14	6		
			0.812	20.6	0.8	20.3	0.43	0.6	0.86	1.22	2.32	4.3	6.8	9.13	10.7	12		
1	25	150 - 1500	0.25	6.4	0.8	20.3	0.05	0.08	0.11	0.18	0.3	0.5	0.8	1.1	1.5	1.7		
			0.375	9.5	0.8	20.3	0.12	0.17	0.24	0.39	0.68	1.13	1.76	2.5	3.26	3.8		
			0.5	12.7	0.8	20.3	0.18	0.27	0.38	0.62	1.07	1.79	2.77	3.95	5.14	6		
			0.812	20.6	0.8	20.3	0.4	0.6	0.86	1.22	2.32	4.3	6.8	9.13	10.7	12		
1.5	40	150 - 1500	0.25	6.4	0.8	20.3	0.05	0.08	0.11	0.18	0.3	0.5	0.8	1.1	1.5	1.7		
			0.375	9.5	0.8	20.3	0.12	0.17	0.24	0.39	0.68	1.13	1.76	2.5	3.26	3.8		
			0.5	12.7	0.8	20.3	0.18	0.27	0.38	0.62	1.07	1.79	2.77	3.95	5.14	6		
			0.812	20.6	0.8	20.3	0.4	0.59	0.82	1.34	2.32	3.87	6.01	8.57	11.1	13		
			0.994	25.2	0.8	20.3	0.43	0.73	1.14	1.73	2.69	4.61	6.93	10.76	14.84	18		
			1.25	31.8	0.8	20.3	0.77	1.13	1.58	2.58	4.46	7.45	11.6	16.5	21.4	25		
2	50	150 - 1500	0.25	6.4	0.8	20.3	0.05	0.08	0.11	0.18	0.3	0.5	0.8	1.1	1.5	1.7		
			0.375	9.5	0.8	20.3	0.12	0.17	0.24	0.39	0.68	1.13	1.76	2.5	3.26	3.8		
			0.5	12.7	0.8	20.3	0.18	0.27	0.38	0.62	1.07	1.79	2.77	3.95	5.14	6		
			0.812	20.6	0.8	20.3	0.46	0.68	0.95	1.55	2.68	4.47	6.93	9.88	12.9	15		
			0.994	25.2	0.8	20.3	0.46	0.77	1.2	1.82	2.84	4.87	7.32	11.36	15.67	19		
			1.25	31.8	0.8	20.3	0.8	1.17	1.64	2.68	4.64	7.75	12	17.1	22.3	26		
3	80	150 - 1500	0.994	25.2	1.5	38.1	0.48	0.81	1.26	1.92	2.99	5.13	7.7	11.96	16.49	20		
			1.25	31.8	1.5	38.1	0.95	1.4	1.96	3.2	5.53	9.24	14.3	20.4	26.6	31		
			1.625	41.3	1.5	38.1	1.45	2.12	2.97	4.85	8.39	14	21.7	31	40.3	47		
			2.000	50.8	1.5	38.1	1.73	2.93	4.55	6.91	10.76	18.45	27.72	43	59.36	72		
			2.625	66.7	1.5	38.1	4	5.5	7.88	11.2	21.2	39.4	62.3	83.7	98.5	110		
			0.994	25.2	1.5	38.1	0.74	1.14	1.76	2.07	2.99	5.13	7.7	11.96	16.49	20		
4	100	150 - 1500	1.625	41.3	1.5	38.1	1.51	2.21	3.09	5.06	8.74	14.6	22.7	32.3	42	49		
			2.000	50.8	1.5	38.1	2.73	4.22	6.51	7.66	11.1	18.97	28.49	44.24	61	74		
			2.625	66.7	1.5	38.1	3.47	5.09	7.14	11.7	20.2	33.7	52.2	74.5	96.8	113		
			3.5	88.9	1.5	38.1	7	9.7	14	19.9	37.6	69.8	110	148	175	195		
			2	50.8	2	50.8	2.99	4.62	7.13	8.38	12.1	20.76	31.19	48.42	66.78	81		
6	150	150 - 600	2.625	66.7	2	50.8	3.87	5.68	7.96	13	22.5	37.5	58.3	83	108	126		
			3.5	88.9	2	50.8	6.4	9.37	13.1	21.5	37.1	62	96.2	137	178	208		
			4.375	111	2	50.8	11	17.1	26.4	31	44.85	76.89	115.5	179.34	247.35	300		
			5	127	2	50.8	14.4	20	28.7	40.7	77.2	143	227	304	358	400		
			3.5	88.9	2	50.8	7	10	15	24	40	72	112	154	197	224		
8	200	150 - 600	4.375	111	2	50.8	8	13	20	31	48	82	123	191	264	320		
			5	127	2	50.8	13	19	28	44	74	133	207	285	365	415		
			6.25	158.7	2.5	63.5	20	30	43	68	115	205	320	440	562	640		

1. Close clearance 0.75 and 1 are available in quick change trim only (Model 21114).
2. Models 21614 and 21615 available only in C_v ranges as indicated by gray background.

C_v and F_L versus Travel

Contoured Plug

Direction: FLOW-TO-OPEN (FTO)
Flow Characteristic: MODIFIED PERCENT

Percent of Travel							10	20	30	40	50	60	70	80	90	100	
F _L							0.93	0.93	0.93	0.93	0.93	0.92	0.92	0.91	0.91	0.91	0.9
Valve Size		ASME Rating	Orifice Diameter		Travel		Rated C _v										
Inch	mm		Inch	mm	Inch	mm											
0.75	20	150 - 1500	0.25	6.4	0.8	20.3	0.04	0.07	0.14	0.28	0.5	0.73	0.99	1.28	1.52	1.7	
			0.375	9.5	0.8	20.3	0.09	0.15	0.31	0.64	1.13	1.64	2.22	2.86	3.4	3.8	
			0.5	12.7	0.8	20.3	0.14	0.24	0.49	1	1.78	2.59	3.5	4.5	5.38	6	
			0.812	20.6	0.8	20.3	0.32	0.74	1.27	3.25	5.47	7.78	9.6	10.85	11.57	12	
1	25	150 - 1500	0.25	6.4	0.8	20.3	0.04	0.07	0.14	0.28	0.5	0.73	0.99	1.28	1.52	1.7	
			0.375	9.5	0.8	20.3	0.09	0.15	0.31	0.64	1.13	1.64	2.22	2.86	3.4	3.8	
			0.5	12.7	0.8	20.3	0.14	0.24	0.49	1	1.78	2.59	3.5	4.5	5.38	6	
			0.812	20.6	0.8	20.3	0.32	0.74	1.27	3.25	5.47	7.78	9.6	10.85	11.57	12	
1.5	40	150 - 1500	0.25	6.4	0.8	20.3	0.04	0.07	0.14	0.28	0.5	0.73	0.99	1.28	1.52	1.7	
			0.375	9.5	0.8	20.3	0.09	0.15	0.31	0.64	1.13	1.64	2.22	2.86	3.4	3.8	
			0.5	12.7	0.8	20.3	0.14	0.24	0.49	1	1.78	2.59	3.5	4.5	5.38	6	
			0.812	20.6	0.8	20.3	0.29	0.52	1.07	2.18	3.86	5.62	7.6	9.77	11.65	13	
			0.994	25.2	0.8	20.3	0.41	0.71	1.48	3.01	5.34	7.78	10.53	13.53	16.13	18	
			1.25	31.8	0.8	20.3	0.68	1.55	2.66	6.77	11.4	16.2	20	22.6	24.11	25	
			1.625	41.3	0.8	20.3	0.95	2.17	3.72	9.48	15.97	22.69	28	31.65	33.76	35	
2	50	150 - 1500	0.25	6.4	0.8	20.3	0.04	0.07	0.14	0.28	0.5	0.73	0.99	1.28	1.52	1.7	
			0.375	9.5	0.8	20.3	0.09	0.15	0.31	0.64	1.13	1.64	2.22	2.86	3.4	3.8	
			0.5	12.7	0.8	20.3	0.14	0.24	0.49	1	1.78	2.59	3.5	4.5	5.38	6	
			0.812	20.6	0.8	20.3	0.34	0.59	1.23	2.51	4.45	6.48	8.77	11.28	13.44	15	
			0.994	25.2	0.8	20.3	0.43	0.75	1.56	3.18	5.64	8.21	11.11	14.28	17	19	
			1.25	31.8	0.8	20.3	0.59	1.03	2.14	4.35	7.71	11.23	15.2	19.54	23.3	26	
			1.625	41.3	0.8	20.3	1.24	2.85	4.89	12.46	20.99	29.82	36.81	41.59	44.37	46	
3	80	150 - 1500	0.994	25.2	1.5	38.1	0.45	0.79	1.64	3.35	5.93	8.64	11.7	15	17.92	20	
			1.25	31.8	1.5	38.1	0.7	1.23	2.55	5.19	9.19	13.4	18.13	23.3	27.78	31	
			1.625	41.3	1.5	38.1	1.06	1.86	3.86	7.87	13.94	20.3	27.49	35.33	42.12	47	
			2.000	50.8	1.5	38.1	1.63	2.85	5.92	12.05	21.36	31.11	42.11	54.12	64.53	72	
			2.625	66.7	1.5	38.1	2.97	6.82	11.68	29.79	50.18	71.3	88	99.46	106.1	110	
4	100	150 - 1500	0.994	25.2	1.5	38.1	0.45	0.79	1.64	3.35	5.93	8.64	11.7	15	17.92	20	
			1.625	41.3	1.5	38.1	1.11	1.94	4.03	8.2	14.53	21.17	28.66	36.83	43.91	49	
			2.000	50.8	1.5	38.1	1.67	2.93	6.08	12.39	21.95	31.98	43.28	55.63	66.32	74	
			2.625	66.7	1.5	38.1	2.56	4.48	9.29	18.92	33.52	48.83	66.09	84.94	101.27	113	
			3.5	88.9	1.5	38.1	5.27	12.1	20.7	52.8	88.96	126.4	156.04	176.32	188.08	195	
6	150	150 - 600	2.000	50.8	2	50.8	1.83	3.21	6.66	13.56	24.02	35	47.38	60.89	72.6	81	
			2.625	66.7	2	50.8	2.85	4.99	10.36	21.1	37.37	54.44	73.7	94.7	112.92	126	
			3.5	88.9	2	50.8	4.71	8.25	17.1	34.82	61.69	89.88	121.66	156.35	186.41	208	
			4.375	111	2	50.8	6.79	11.89	24.66	50.22	88.98	129.63	175.47	225.51	268.86	300	
			5	127	2	50.8	10.8	24.8	42.48	108.32	182.48	259.28	320.08	361.68	385.8	400	

C_v and F_L versus Travel

Contoured Plug

Direction: FLOW-TO-CLOSE (FTC)
Flow Characteristic: LINEAR TRIM

Percent of Travel							10	20	30	40	50	60	70	80	90	100
F _L							0.53	0.56	0.60	0.68	0.75	0.78	0.81	0.84	0.85	0.86
Valve Size		ASME Rating	Orifice Diameter		Travel		Rated C _v									
Inch	mm		Inch	mm	Inch	mm										
0.75	20	150 - 1500	0.25	6.4	0.8	20.3	0.225	0.39	0.46	0.61	0.77	0.94	1.12	1.31	1.5	1.7
			0.375	9.5	0.8	20.3	0.51	0.85	1.02	1.36	1.72	2.11	2.51	2.93	3.36	3.8
			0.5	12.7	0.8	20.3	0.81	1.34	1.6	2.15	2.72	3.33	3.96	4.62	5.3	6
			0.812	20.6	0.8	20.3	1.635	2.69	3.21	4.3	5.45	6.65	7.92	9.24	10.6	12
1	25	150 - 1500	0.25	6.4	0.8	20.3	0.225	0.39	0.46	0.61	0.77	0.94	1.12	1.31	1.5	1.7
			0.375	9.5	0.8	20.3	0.51	0.85	1.02	1.36	1.73	2.11	2.51	2.93	3.36	3.8
			0.5	12.7	0.8	20.3	0.81	1.35	1.61	2.15	2.72	3.33	4	4.63	5.31	6
			0.812	20.6	0.8	20.3	1.635	2.70	3.22	4.31	5.45	6.66	7.93	9.25	10.6	12
1.5	40	150 - 1500	0.25	6.4	0.8	20.3	0.225	0.39	0.46	0.61	0.77	0.94	1.12	1.31	1.5	1.7
			0.375	9.5	0.8	20.3	0.51	0.85	1.02	1.36	1.73	2.11	2.51	2.93	3.36	3.8
			0.5	12.7	0.8	20.3	0.81	1.35	1.61	2.15	2.72	3.33	4	4.63	5.31	6
			0.812	20.6	0.8	20.3	1.77	2.91	3.48	4.66	5.9	7.2	8.58	10	11.5	13
			0.994	25.2	0.8	20.3	3.15	5.22	6.1	7.91	9.89	11.67	13.65	15.39	16.65	18
			1.25	31.8	0.8	20.3	3.40	5.61	6.7	8.97	11.3	13.9	16.5	19.3	22.1	25
2	50	150 - 1500	0.25	6.4	0.8	20.3	0.225	0.39	0.46	0.61	0.77	0.94	1.12	1.31	1.5	1.7
			0.375	9.5	0.8	20.3	0.51	0.85	1.02	1.36	1.73	2.11	2.51	2.93	3.36	3.8
			0.5	12.7	0.8	20.3	0.81	1.35	1.61	2.15	2.72	3.33	4	4.63	5.31	6
			0.812	20.6	0.8	20.3	2.04	3.38	4.02	5.38	6.81	8.32	9.91	11.6	13.3	15
			0.994	25.2	0.8	20.3	3.33	5.51	6.4	8.35	10.44	12.3	14.4	16.25	17.58	19
			1.25	31.8	0.8	20.3	3.54	5.84	6.97	9.33	11.8	14.4	17.2	20.1	23	26
3	80	150 - 1500	0.994	25.2	1.5	38.1	3.5	5.8	6.74	8.79	11	12.97	15.2	17.1	18.5	20
			1.25	31.8	1.5	38.1	4.22	6.96	8.31	11.1	14.1	17.2	20.5	23.9	27.4	31
			1.625	41.3	1.5	38.1	6.39	10.56	12.6	16.9	21.3	26.1	31.1	36.2	41.6	47
			2.000	50.8	1.5	38.1	12.6	20.9	24.26	31.65	39.57	46.68	54.58	61.57	66.6	72
			2.625	66.7	1.5	38.1	14.96	24.75	29.5	39.5	49.9	61	72.7	84.8	97.3	110
			0.994	25.2	1.5	38.1	3.5	5.8	6.74	8.79	11	12.97	15.2	17.1	18.5	20
4	100	150 - 1500	1.625	41.3	1.5	38.1	6.66	11.01	13.1	17.6	22.3	27.2	32.4	37.8	43.3	49
			2.000	50.8	1.5	38.1	12.95	21.46	24.93	32.53	40.67	47.97	56.1	63.28	68.45	74
			2.625	66.7	1.5	38.1	15.45	25.38	30.3	40.6	51.3	62.7	74.7	87.1	99.9	113
			3.5	88.9	1.5	38.1	26.55	43.88	52.3	70	88.6	108	129	150	172	195
			2.000	50.8	2	50.	14.18	23.49	27.29	35.6	44.5	52.5	61.4	69.2	74.9	81
6	150	150 - 600	2.625	66.7	2	50.	17.1	28.38	33.8	45.2	57.2	69.9	83.2	97.2	111	126
			3.5	88.9	2	50.	28.35	46.75	55.7	74.6	94.5	115	137	160	184	208
			4.375	111	2	50.	52.5	87	101	131.9	164.9	194.5	227.4	256.5	277.5	300
			5	127	2	50.	54.45	89.88	107	143	182	222	264	308	354	400
			3.5	88.9	2	50.	30	50	60	80	101	124	148	172	197	224
8	200	150 - 600	4.375	111	2	50.	54.5	92.8	108	141	176	207	243	274	296	320
			5	127	2	50.	55.5	93.75	112	148	187	230	274	319	365	415
			6.25	158.7	2.5	63.	85.5	143.7	173	228	289	355	422	493	563	640

1. Close clearance 0.75 and 1 are available in quick change trim only (Model 21114).
2. Models 21614 and 21615 available only in Cv ranges as indicated by gray background.

C_v and F_L versus Travel

Contoured Plug

Direction: FLOW-TO-CLOSE (FTC)
Flow Characteristic: EQUAL PERCENT

Percent of Travel							10	20	30	40	50	60	70	80	90	100		
F _L							0.53	0.53	0.55	0.63	0.72	0.80	0.80	0.80	0.80	0.80	0.80	
Valve Size		ASME Rating	Orifice Diameter		Travel		Rated C _v											
Inch	mm		Inch	mm	Inch	mm												
0.75	20	150 - 1500	0.25	6.4	0.8	20.3	0.1	0.1	0.2	0.22	0.3	0.5	0.8	1.1	1.5	1.7		
			0.375	9.5	0.8	20.3	0.2	0.2	0.3	0.39	0.68	1.13	1.76	2.5	3.26	3.8		
			0.5	12.7	0.8	20.3	0.3	0.4	0.5	0.64	1.07	1.79	2.77	3.95	5.14	6		
			0.812	20.6	0.8	20.3	0.6	0.8	1.2	1.48	2.32	4.3	6.8	9.13	10.7	12		
1	25	150 - 1500	0.25	6.4	0.8	20.3	0.1	0.1	0.2	0.22	0.3	0.5	0.8	1.1	1.5	1.7		
			0.375	9.5	0.8	20.3	0.2	0.2	0.3	0.39	0.68	1.13	1.76	2.5	3.26	3.8		
			0.5	12.7	0.8	20.3	0.3	0.4	0.5	0.64	1.07	1.79	2.77	3.95	5.14	6		
			0.812	20.6	0.8	20.3	0.6	0.8	1.2	1.48	2.32	4.3	6.8	9.13	10.7	12		
1.5	40	150 - 1500	0.25	6.4	0.8	20.3	0.1	0.1	0.2	0.22	0.3	0.5	0.8	1.1	1.5	1.7		
			0.375	9.5	0.8	20.3	0.2	0.2	0.3	0.39	0.68	1.13	1.76	2.5	3.26	3.8		
			0.5	12.7	0.8	20.3	0.3	0.4	0.5	0.64	1.07	1.79	2.77	3.95	5.14	6		
			0.812	20.6	0.8	20.3	0.6	0.8	1.1	1.48	2.32	3.87	6.01	8.57	11.1	13		
			0.994	25.2	0.8	20.3	0.66	1.03	1.58	1.86	2.69	4.61	6.93	10.76	14.84	18		
			1.25	31.8	0.8	20.3	1.2	1.6	2.2	2.76	4.46	7.45	11.6	16.5	21.4	25		
2	50	150 - 1500	1.625	41.3	0.8	20.3	2.0	2.4	3.5	4.31	6.76	12.5	19.8	26.6	31.3	35		
			0.25	6.4	0.8	20.3	0.1	0.1	0.2	0.22	0.3	0.5	0.8	1.1	1.5	1.7		
			0.375	9.5	0.8	20.3	0.2	0.2	0.3	0.39	0.68	1.13	1.76	2.5	3.26	3.8		
			0.5	12.7	0.8	20.3	0.3	0.4	0.5	0.64	1.07	1.79	2.77	3.95	5.14	6		
			0.812	20.6	0.8	20.3	0.7	1.0	1.3	1.64	2.68	4.47	6.93	9.88	12.9	15		
			0.994	25.2	0.8	20.3	0.7	1.08	1.67	1.97	2.84	4.87	7.32	11.36	15.67	19		
3	80	150 - 1500	1.25	31.8	0.8	20.3	1.2	1.6	2.3	2.76	4.64	7.75	12	17.1	22.3	26		
			1.625	41.3	0.8	20.3	2.6	3.2	4.6	5.67	8.88	16.5	26.1	35	41.2	46		
			0.994	25.2	1.5	38.1	0.74	1.14	1.76	2.07	2.99	5.13	7.7	11.96	16.49	20		
			1.25	31.8	1.5	38.1	1.4	2.0	2.7	3.4	5.53	9.24	14.3	20.4	26.6	31		
			1.625	41.3	1.5	38.1	2.2	3.0	4.2	5.24	8.39	14	21.7	31	40.3	47		
4	100	150 - 1500	2.000	50.8	1.5	38.1	2.66	4.1	6.34	7.45	10.76	18.45	27.72	43	59.36	72		
			2.625	66.7	1.5	38.1	6.0	7.7	11.0	13.5	21.2	39.4	62.3	83.7	98.5	110		
			0.994	25.2	1.5	38.1	0.74	1.14	1.76	2.07	2.99	5.13	7.7	11.96	16.49	20		
			1.625	41.3	1.5	38.1	2.3	3.1	4.3	5.41	8.74	14.6	22.7	32.3	42	49		
			2.000	50.8	1.5	38.1	2.73	4.22	6.51	7.66	11.1	18.97	28.49	44.24	61	74		
6	150	150 - 600	2.625	66.7	1.5	38.1	5.2	7.1	10.0	12.55	20.2	33.7	52.2	74.5	96.8	113		
			3.5	88.9	1.5	38.1	10.5	13.6	19.6	24.1	37.6	69.8	110	148	175	195		
			2.000	50.8	2	50.8	3	4.62	7.13	8.38	12.1	20.76	31.19	48.42	66.78	81		
			2.625	66.7	2	50.8	5.8	8.0	11.1	13.9	22.5	37.5	58.3	83	108	126		
			3.5	88.9	2	50.8	9.6	13.1	18.3	23	37.1	62	96.2	137	178	208		
8	200	150 - 600	4.375	111	2	50.8	11.1	17.1	26.4	31	44.85	76.89	115.5	179.34	247.35	300		
			5	127	2	50.8	21.6	28.0	40.2	49.4	77.2	143	227	304	358	400		
			3.5	88.9	2	50.8	10.5	14.0	21.0	25.75	40	72	112	154	197	224		
			4.375	111	2	50.8	11.8	18.2	28.2	33.1	48	82	123	191	264	320		
			6.25	158.7	2.5	63.5	30.0	42.0	60.2	73.9	115	205	320	440	562	640		

1. Close clearance 0.75 and 1 are available in quick change trim only (Model 21114).
2. Models 21614 and 21615 available only in C_v ranges as indicated by gray background.

C_v and F_L versus Travel

Contoured Plug

Direction: FLOW-TO-CLOSE (FTC)
Flow Characteristic: MODIFIED PERCENT

Percent of Travel							10	20	30	40	50	60	70	80	90	100	
F _L							0.53	0.53	0.55	0.63	0.72	0.80	0.80	0.80	0.80	0.80	0.80
Valve Size		ASME Rating	Orifice Diameter		Travel		Rated C _v										
Inch	mm		Inch	mm	Inch	mm											
0.75	20	150 - 1500	0.25	6.4	0.8	20.3	0.06	0.09	0.19	0.3	0.5	0.73	0.99	1.28	1.52	1.7	
			0.375	9.5	0.8	20.3	0.13	0.21	0.43	0.68	1.13	1.64	2.22	2.86	3.4	3.8	
			0.5	12.7	0.8	20.3	0.2	0.33	0.68	1.08	1.78	2.59	3.51	4.51	5.38	6	
			0.812	20.6	0.8	20.3	0.48	1.03	1.79	3.91	5.47	7.78	9.6	10.85	11.57	12	
1	25	150 - 1500	0.25	6.4	0.8	20.3	0.06	0.09	0.19	0.3	0.5	0.73	0.99	1.28	1.52	1.7	
			0.375	9.5	0.8	20.3	0.13	0.21	0.43	0.68	1.13	1.64	2.22	2.86	3.4	3.8	
			0.5	12.7	0.8	20.3	0.2	0.33	0.68	1.08	1.78	2.59	3.51	4.51	5.38	6	
			0.812	20.6	0.8	20.3	0.48	1.03	1.79	3.91	5.47	7.78	9.6	10.85	11.57	12	
1.5	40	150 - 1500	0.25	6.4	0.8	20.3	0.06	0.09	0.19	0.3	0.5	0.73	0.99	1.28	1.52	1.7	
			0.375	9.5	0.8	20.3	0.13	0.21	0.43	0.68	1.13	1.64	2.22	2.86	3.4	3.8	
			0.5	12.7	0.8	20.3	0.2	0.33	0.68	1.08	1.78	2.59	3.51	4.51	5.38	6	
			0.812	20.6	0.8	20.3	0.44	0.72	1.48	2.34	3.86	5.62	7.6	9.77	11.65	13	
			0.994	25.2	0.8	20.3	0.61	0.99	2.05	3.24	5.34	7.78	10.53	13.53	16.13	18	
			1.25	31.8	0.8	20.3	1	2.15	3.73	8.15	11.4	16.2	20	22.6	24.11	25	
2	50	150 - 1500	0.25	6.4	0.8	20.3	0.06	0.09	0.19	0.3	0.5	0.73	0.99	1.28	1.52	1.7	
			0.375	9.5	0.8	20.3	0.13	0.21	0.43	0.68	1.13	1.64	2.22	2.86	3.4	3.8	
			0.5	12.7	0.8	20.3	0.2	0.33	0.68	1.08	1.78	2.59	3.51	4.51	5.38	6	
			0.812	20.6	0.8	20.3	0.51	0.83	1.71	2.7	4.45	6.48	8.77	11.28	13.44	15	
			0.994	25.2	0.8	20.3	0.65	1.05	2.17	3.42	5.64	8.21	11.11	14.28	17	19	
			1.25	31.8	0.8	20.3	0.88	1.43	2.96	4.68	7.71	11.23	15.2	19.54	23.3	26	
3	80	150 - 1500	1.625	41.3	0.8	20.3	1.4	3	5.2	11.4	15.97	22.69	28	31.65	33.76	35	
			0.994	25.2	1.5	38.1	0.68	1.1	2.28	3.6	5.93	8.64	11.7	15	17.92	20	
			1.25	31.8	1.5	38.1	1.05	1.7	3.53	5.58	9.19	13.4	18.13	23.3	27.78	31	
			1.625	41.3	1.5	38.1	1.6	2.59	5.36	8.46	13.94	20.31	27.49	35.33	42.12	47	
			2.000	50.8	1.5	38.1	2.45	3.96	8.21	12.96	21.36	31.11	42.11	54.12	64.53	72	
4	100	150 - 1500	2.625	66.7	1.5	38.1	4.4	9.46	16.39	35.86	50.18	71.3	88	99.46	106.1	110	
			0.994	25.2	1.5	38.1	0.68	1.1	2.28	3.6	5.93	8.64	11.7	15	17.92	20	
			1.625	41.3	1.5	38.1	1.67	2.7	5.59	8.82	14.53	21.17	28.66	36.83	43.91	49	
			2.000	50.8	1.5	38.1	2.52	4.07	8.43	13.32	21.95	31.98	43.28	55.63	66.32	74	
			2.625	66.7	1.5	38.1	3.84	6.22	12.88	20.34	33.52	48.83	66.94	84.9	101	113	
6	150	150 - 600	3.5	88.9	1.5	38.1	7.8	16.77	29.1	63.57	88.96	126.4	156	176	188	195	
			2.000	50.8	2	50.8	2.75	4.46	9.23	14.58	24.02	35	47.38	60.89	72.59	81	
			2.625	66.7	2	50.8	4.28	6.93	14.36	22.68	37.37	54.44	73.7	94.71	113	126	
			4.375	111	2	50.8	10.2	16.5	34.2	54	88.98	129.63	175.47	225.51	269	300	
			5	127	2	50.8	16	34.4	59.6	130.4	182.48	259.28	320.1	361.68	386	400	

C_v and F_L versus Travel

Direction: FLOW-TO-OPEN (FTO)

Flow Characteristic: LINEAR

Rating: ASME 2500 (PN 420)

Contoured Plug

Percent of Travel							10	20	30	40	50	60	70	80	90	100	
F _L							0.93	0.93	0.92	0.92	0.91	0.91	0.91	0.9	0.9	0.9	0.90
Valve Size		ASME Rating	Orifice Diameter		Travel		Rated C _v										
Inch	mm		Inch	mm	Inch	mm											
0.75	20	2500	0.25	6.4	0.8	20.3	0.15	0.31	0.46	0.61	0.77	0.94	1.12	1.31	1.5	1.7	
			0.375	9.5	0.8	20.3	0.34	0.68	1.02	1.36	1.7	2.11	2.5	2.9	3.4	3.8	
			0.5	12.7	0.8	20.3	0.54	1.07	1.60	2.2	2.7	3.33	4	4.6	5.30	6	
			0.812	20.6	0.8	20.3	0.70	1.40	2.20	2.80	3.60	4.40	5.30	6.20	7.00	8	
1	25	2500	0.25	6.4	0.8	20.3	0.15	0.31	0.46	0.61	0.77	0.94	1.12	1.31	1.50	1.7	
			0.375	9.5	0.8	20.3	0.34	0.68	1.02	1.36	1.73	2.11	2.5	2.9	3.4	3.8	
			0.5	12.7	0.8	20.3	0.54	1.08	1.61	2.2	2.7	3.33	4.0	4.6	5.3	6	
			0.812	20.6	0.8	20.3	0.9	1.8	2.7	3.6	4.5	5.6	6.6	7.7	9	10	
1.5	40	2500	0.25	6.4	0.8	20.3	0.15	0.31	0.46	0.61	0.77	0.94	1.12	1.31	1.50	1.7	
			0.375	9.5	0.8	20.3	0.34	0.68	1.02	1.36	1.7	2.11	2.5	2.93	3.4	3.8	
			0.5	12.7	0.8	20.3	0.54	1.08	1.61	2.15	2.7	3.33	4.0	4.6	5.3	6	
			0.812	20.6	0.8	20.3	1.18	2.3	3.5	4.7	5.9	7.2	8.6	10	11.5	13	
			0.994	25.2	0.8	20.3	2.1	4.2	6.1	7.9	9.9	11.7	13.7	15.4	16.7	18	
			1.25	31.8	0.8	20.3	2.3	4.5	6.7	9.0	11.3	13.9	16.5	19.3	22.1	25	
2	50	2500	0.25	6.4	0.8	20.3	0.15	0.31	0.46	0.61	0.77	0.94	1.12	1.31	1.50	1.7	
			0.375	9.5	0.8	20.3	0.34	0.68	1.02	1.36	1.7	2.11	2.5	2.9	3.4	3.8	
			0.5	12.7	0.8	20.3	0.54	1.08	1.61	2.2	2.7	3.33	4.0	4.6	5.3	6	
			0.812	20.6	0.8	20.3	1.4	2.7	4.0	5.4	6.8	8.3	9.9	11.6	13.3	15	
			0.994	25.2	0.8	20.3	2.2	4.4	6.4	8.4	10.4	12.3	14.4	16.3	17.6	19	
			1.25	31.8	0.8	20.3	2.4	4.7	7.0	9.3	11.8	14.4	17.2	20.1	23	26	
			1.625	41.3	0.8	20.3	3.2	6.3	9	12	16	19	23	27	31	35	

1. Close clearance 0.75 and 1 are available in quick change trim only (Model 21114).
2. Models 21614 and 21615 available only in C_v ranges as indicated by gray background.

C_v and F_L versus Travel

Direction: FLOW-TO-OPEN (FTO)
 Flow Characteristic: EQUAL PERCENT
 Rating: ASME 2500 (PN 420)

Contoured Plug

Percent of Travel							10	20	30	40	50	60	70	80	90	100	
F _L							0.93	0.93	0.93	0.93	0.93	0.92	0.92	0.91	0.91	0.91	0.90
Valve Size		ASME Rating	Orifice Diameter		Travel		Rated C _v										
Inch	mm		Inch	mm	Inch	mm											
0.75	20	2500	0.25	6.4	0.8	20.3	0.05	0.08	0.11	0.18	0.3	0.5	0.8	1.1	1.5	1.7	
			0.375	9.5	0.8	20.3	0.12	0.17	0.24	0.39	0.68	1.13	1.76	2.5	3.26	3.8	
			0.5	12.7	0.8	20.3	0.18	0.27	0.38	0.62	1.07	1.79	2.77	3.95	5.14	6	
			0.812	20.6	0.8	20.3	0.29	0.41	0.56	0.9	1.5	2.9	4.5	6	7	8	
1	25	2500	0.25	6.4	0.8	20.3	0.05	0.08	0.11	0.18	0.3	0.5	0.8	1.1	1.5	1.7	
			0.375	9.5	0.8	20.3	0.12	0.17	0.24	0.39	0.68	1.13	1.76	2.5	3.26	3.8	
			0.5	12.7	0.8	20.3	0.18	0.27	0.38	0.62	1.07	1.79	2.77	3.95	5.14	6	
			0.812	20.6	0.8	20.3	0.36	0.51	0.7	1.1	1.9	3.6	5.6	7.4	9	10	
1.5	40	2500	0.25	6.4	0.8	20.3	0.05	0.08	0.11	0.18	0.3	0.5	0.8	1.1	1.5	1.7	
			0.375	9.5	0.8	20.3	0.12	0.17	0.24	0.39	0.68	1.13	1.76	2.5	3.26	3.8	
			0.5	12.7	0.8	20.3	0.18	0.27	0.38	0.62	1.07	1.79	2.77	3.95	5.14	6	
			0.812	20.6	0.8	20.3	0.4	0.59	0.82	1.34	2.32	3.87	6.01	8.57	11.1	13	
			0.994	25.2	0.8	20.3	0.43	0.73	1.14	1.73	2.69	4.61	6.93	10.76	14.84	18	
			1.25	31.8	0.8	20.3	0.72	1.02	1.4	2.2	3.8	7.2	11	15	18	20	
2	50	2500	0.25	6.4	0.8	20.3	0.05	0.08	0.11	0.18	0.3	0.5	0.8	1.1	1.5	1.7	
			0.375	9.5	0.8	20.3	0.12	0.17	0.24	0.39	0.68	1.13	1.76	2.5	3.26	3.8	
			0.5	12.7	0.8	20.3	0.18	0.27	0.38	0.62	1.07	1.79	2.77	3.95	5.14	6	
			0.812	20.6	0.8	20.3	0.46	0.68	0.95	1.55	2.68	4.47	6.93	9.88	12.9	15	
			0.994	25.2	0.8	20.3	0.46	0.77	1.2	1.82	2.84	4.87	7.32	11.36	15.67	19	
			1.25	31.8	0.8	20.3	0.8	1.17	1.64	2.68	4.64	7.75	12	17.1	22.3	26	
			1.625	41.3	0.8	20.3	1.3	1.8	2.5	3.9	6.6	13	20	26	31	35	

1. Close clearance 0.75 and 1 are available in quick change trim only (Model 21114).
2. Models 21614 and 21615 available only in C_v ranges as indicated by gray background.

C_v and F_L versus Travel

Direction: FLOW-TO-OPEN (FTO)
 Flow Characteristic: MODIFIED PERCENT
 Rating: ASME 2500 (PN 420)

Contoured Trim

Percent of Travel							10	20	30	40	50	60	70	80	90	100
F _L							0.93	0.93	0.93	0.93	0.93	0.92	0.92	0.91	0.91	0.90
Valve Size		ASME Rating	Orifice Diameter		Travel		Rated C _v									
Inch	mm		Inch	mm	Inch	mm										
0.75	20	2500	0.25	6.4	0.8	20.3	0.04	0.07	0.14	0.28	0.5	0.73	0.99	1.28	1.52	1.7
			0.375	9.5	0.8	20.3	0.09	0.15	0.31	0.64	1.13	1.64	2.22	2.86	3.4	3.8
			0.5	12.7	0.8	20.3	0.14	0.24	0.49	1	1.78	2.59	3.5	4.5	5.38	6
			0.812	20.6	0.8	20.3	0.21	0.49	0.87	2.17	3.65	5.19	6.4	7.23	7.71	8
1	25	2500	0.25	6.4	0.8	20.3	0.04	0.07	0.14	0.28	0.5	0.73	0.99	1.28	1.52	1.7
			0.375	9.5	0.8	20.3	0.09	0.15	0.31	0.64	1.13	1.64	2.22	2.86	3.4	3.8
			0.5	12.7	0.8	20.3	0.14	0.24	0.49	1	1.78	2.59	3.5	4.5	5.38	6
			0.812	20.6	0.8	20.3	0.26	0.58	1.06	2.71	4.56	6.48	8.0	9.04	9.64	10
1.5	40	2500	0.25	6.4	0.8	20.3	0.04	0.07	0.14	0.28	0.5	0.73	0.99	1.28	1.52	1.7
			0.375	9.5	0.8	20.3	0.09	0.15	0.31	0.64	1.13	1.64	2.22	2.86	3.4	3.8
			0.5	12.7	0.8	20.3	0.14	0.24	0.49	1	1.78	2.59	3.5	4.5	5.38	6
			0.812	20.6	0.8	20.3	0.29	0.52	1.07	2.18	3.86	5.62	7.6	9.77	11.65	13
			0.994	25.2	0.8	20.3	0.41	0.71	1.48	3.01	5.34	7.78	10.53	13.53	16.13	18
			1.25	31.8	0.8	20.3	0.68	1.55	2.66	6.77	11.4	16.2	20	22.6	24.11	25
2	50	2500	0.25	6.4	0.8	20.3	0.04	0.07	0.14	0.28	0.5	0.73	0.99	1.28	1.52	1.7
			0.375	9.5	0.8	20.3	0.09	0.15	0.31	0.64	1.13	1.64	2.22	2.86	3.4	3.8
			0.5	12.7	0.8	20.3	0.14	0.24	0.49	1	1.78	2.59	3.5	4.5	5.38	6
			0.812	20.6	0.8	20.3	0.34	0.59	1.23	2.51	4.45	6.48	8.77	11.28	13.44	15
			0.994	25.2	0.8	20.3	0.43	0.75	1.56	3.18	5.64	8.21	11.11	14.28	17	19
			1.25	31.8	0.8	20.3	0.59	1.03	2.14	4.35	7.71	11.23	15.2	19.54	23.3	26

Note:

1. 2 inch size valve with 2 inch (50.8mm) orifice diameter is only available with quick change trim for ASME Class 150 to 600.
2. The .75 and 1 inch valves with C_v 8 is available in quick change trim only.

C_v and F_L versus Travel

Single Stage Lo-dB* / Anti-Cavitation Trim
Single Stage Cavitation Containment

Direction: FLOW-TO-OPEN (FTO) Lo-dB
FLOW-TO-CLOSE (FTC) ANTI/CAV
Flow Characteristic: LINEAR

Percent of Travel							10	20	30	40	50	60	70	80	90	100	
F _L							0.93	0.93	0.93	0.93	0.93	0.93	0.93	0.93	0.93	0.93	0.93
Valve Size		ASME Rating	Orifice Diameter		Travel		Rated C _v										
Inch	mm		Inch	mm	Inch	mm											
0.75	20	150 - 2500	0.812	20.26	0.8	20.3	0.24	0.56	0.96	1.44	2.08	2.68	3.2	3.56	3.84	4	
							0.48	1.12	1.92	2.88	4.16	5.36	6.4	7.12	7.68	8	
1	25	150 - 2500	0.812	20.26	0.8	20.3	0.24	0.56	0.96	1.44	2.08	2.68	3.2	3.56	3.84	4	
							0.48	1.12	1.92	2.88	4.16	5.36	6.4	7.12	7.68	8	
1.5	40	150 - 2500	1.25	31.8	0.8	20.3	0.48	1.12	1.92	2.88	4.16	5.36	6.4	7.12	7.68	8	
							0.9	2.1	3.6	5.4	7.8	10.1	12.0	13.4	14.4	15	
2	50	150 - 2500	1.25	31.8	0.8	20.3	0.48	1.12	1.92	2.88	4.16	5.36	6.4	7.12	7.68	8	
							0.9	2.1	3.6	5.4	7.8	10.1	12.0	13.4	14.4	15	
							1.625	41.3	0.8	20.3	1.5	3.5	6.0	9	13	16.8	20
3	80	150 - 1500	2.00 ¹	50.8	0.8	20.3	1.8	4.2	7.2	10.8	15.6	20.2	24	26.8	28.8	30	
							1.5	38.1	11.5	17.3	24.9	32.2	38.4	42.7	46.1	48	
							2.625	66.7	1.5	38.1	4.5	10.5	18	27	39	50.3	60
4	100	150 - 1500	2.00	50.8	1.5	38.1	1.8	4.2	7.2	10.8	15.6	20.2	24	26.8	28.8	30	
							3.8	8.8	15.1	22.7	32.8	42.2	50.4	56.1	60.5	63	
							3.50	88.9	6	14	24	36	52	67	80	89	96
6	150	150 - 600	5.00	127.0	2	50.4	9	21	36	54	78	101	120	134	144	150	
							12	28	48	72	104	134	160	178	192	200	
8	200	150 - 600	6.25	157.8	2.5	63.5	18	31	65	98	120	161	196	228	263	290	

Note:

1. 2 inch size valve with 2 inch (50.8mm) orifice diameter is only available with quick change trim for ASME Class 150 to 600.
2. The .75 and 1 inch valves with Cv 8 is available in quick change trim only.

C_v and F_L versus Travel

Double Stage Anti-Cavitation Trim

Direction: FLOW-TO-CLOSE (FTC)
Flow Characteristic: LINEAR

Percent of Travel							10	20	30	40	50	60	70	80	90	100	
F _L							0.975	0.975	0.975	0.975	0.975	0.975	0.975	0.975	0.975	0.975	0.975
Valve Size		ASME Rating	Orifice Diameter		Travel		Rated C _v										
inch	mm		inch	mm	inch	mm											
0.75	20	150-2500	0.812	20.6	0.8	20.3	0.14	0.32	0.55	0.83	1.2	1.54	1.8	2.1	2.2	2.3	
							0.27	0.63	1.08	1.62	2.3	3	3.6	4	4.3	4.5	
1	25	150-2500	0.812	20.6	0.8	20.3	0.14	0.32	0.55	0.83	1.2	1.54	1.8	2.1	2.2	2.3	
							0.27	0.63	1.08	1.62	2.3	3	3.6	4	4.3	4.5	
1.5	40	150-2500	0.812	20.6	0.8	20.3	0.14	0.32	0.55	0.83	1.2	1.54	1.8	2.1	2.2	2.3	
							0.27	0.63	1.08	1.62	2.3	3	3.6	4	4.3	4.5	
			1.25	31.8	0.8	20.3	0.51	1.19	2	3.1	4.4	5.7	6.8	7.6	8.2	8.5	
2	50	150-2500	1.25	31.8	0.8	20.3	0.27	0.63	1.08	1.62	2.3	3	3.6	4	4.3	4.5	
							0.51	1.19	2	3.1	4.4	5.7	6.8	7.6	8.2	8.5	
			1.625	41.3	0.8	20.3	0.8	1.9	3.4	5	7.3	9.4	11.2	12.5	13.4	14	
3	80	150-1500	2.625	66.7	1.5	38.1	1.6	3.8	6.4	9.7	14.1	18.1	21.6	24	25.9	27	
							2.5	5.9	10.1	15.1	21.8	28.1	33.6	37.4	40.3	42	
4	100	150-1500	2.625	66.7	1.5	38.1	2.4	5.6	9.6	14.4	20.8	26.8	32	35.6	38.4	40	
							3.7	8.7	14.9	22.3	32.2	41.5	49.6	55.2	59.5	62	

Double stage anti-cavitation trim not available with Bellows Seal construction.

Double Stage Lo-dB* Trim

Direction: FLOW-TO-OPEN (FTO)
Flow Characteristic: LINEAR

Percent of Travel							10	20	30	40	50	60	70	80	90	100
F _L							0.95	0.95	0.95	0.95	0.95	0.95	0.95	0.95	0.95	0.95
Valve Size		ASME Rating	Orifice Diameter		Travel		Rated C _v									
inch	mm		inch	mm	inch	mm										
0.75	20	150-2500	0.812	20.6	0.8	20.3	0.21	0.49	0.84	1.26	1.8	2.4	2.8	3.1	3.4	3.5
							0.34	0.8	1.37	2.1	3	3.8	4.6	5.1	5.5	5.7
1	25	150-2500	0.812	20.6	0.8	20.3	0.21	0.49	0.84	1.26	1.8	2.4	2.8	3.1	3.4	3.5
							0.34	0.8	1.37	2.1	3	3.8	4.6	5.1	5.5	5.7
1.5	40	150-2500	1.25	31.8	0.8	20.3	0.42	0.98	1.68	2.5	3.6	4.7	5.6	6.2	6.7	7
							0.8	1.8	3.1	4.7	6.8	8.7	10.4	11.6	12.5	13
2	50	150-2500	1.25	31.8	0.8	20.3	0.8	1.8	3.1	4.7	6.8	8.7	10.4	11.6	12.5	13
							1.3	2.9	5	7.6	10.9	14.1	16.8	18.7	20.2	21
3	80	150-1500	2.625	66.7	1.5	38.1	2.4	5.6	9.6	14.4	20.8	26.8	32	35.6	38.4	40
							3.5	8.8.9	15.1	22.7	32.8	42.2	50.4	56.1	60.5	63
4	100	150-1500	2.625	66.7	1.5	38.1	3.2	7.4	12.7	19.1	27.6	35.5	42.4	47.2	50.9	53
							4.9	11.6	19.9	29.9	43.2	55.6	66.4	73.9	79.7	83
6	150	150-600	3.5	88.9	1.5	38.1	7.5	17.5	30	45	65	84	100	111	120	125



Single Stage Lo-dB* /
Anti-Cavitation Trim

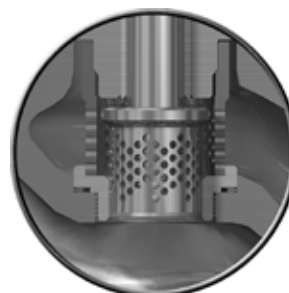

Double Stage Lo-dB* /
Anti-Cavitation Trim

Materials of Construction

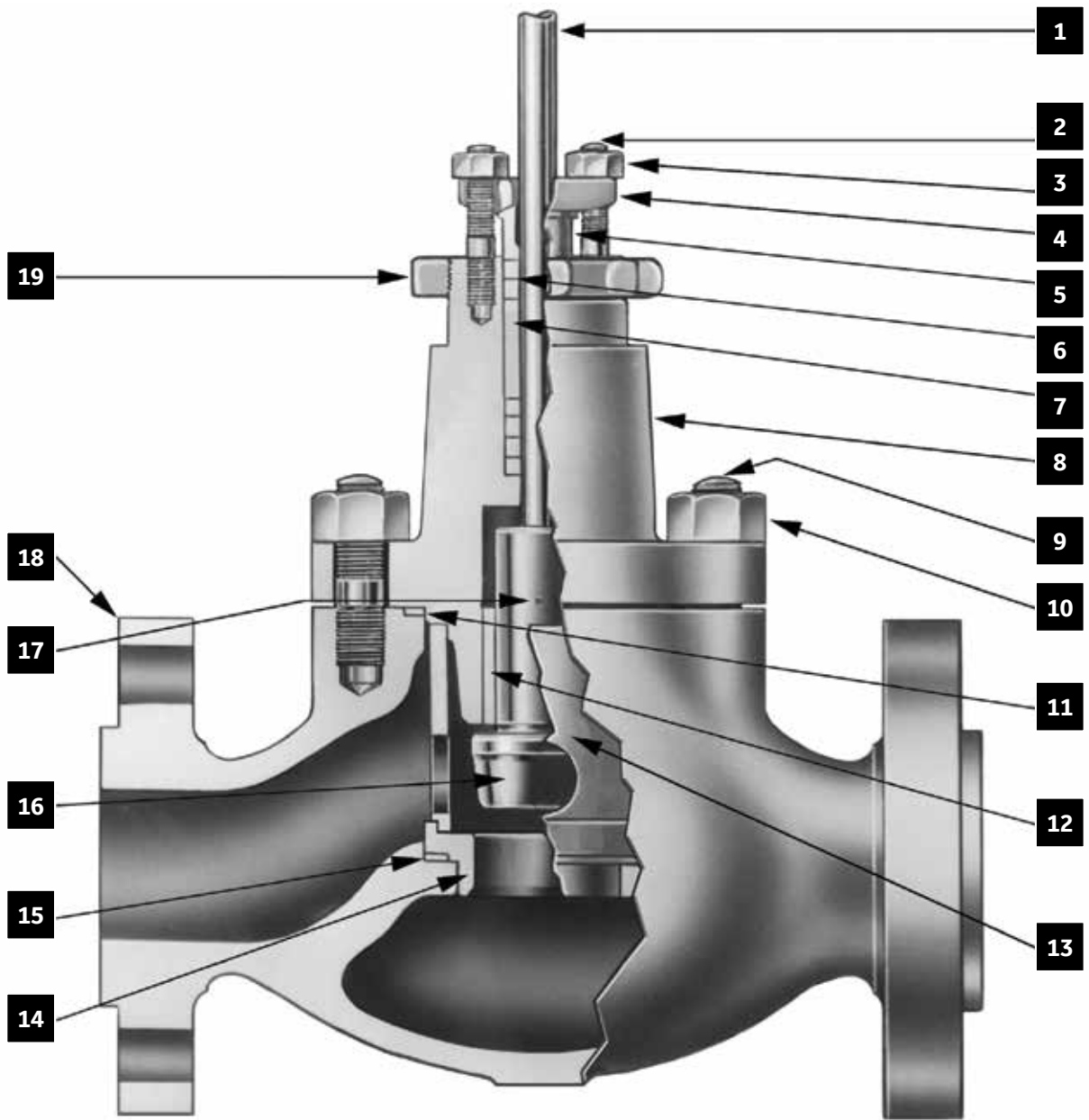

Standard Construction

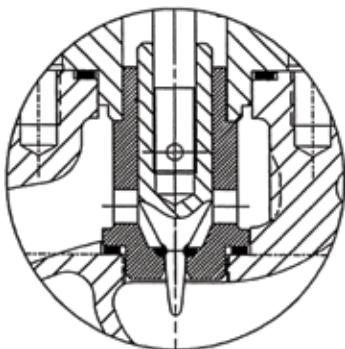

**21000 Close Clearance
Low Flow Trim**

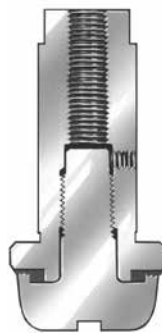

**Soft Seated
Plug S/A**

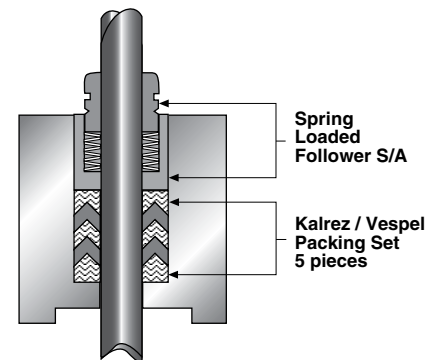

**LE Packing System (Optional)
Low Emission Stem Packing**

Materials of Construction

Standard Carbon Steel Version

Ref. No.	Temperature Range	-20°F (-29°C)	450°F (232°C)	650°F (343°C)	800°F (427°C)	
		Standard Materials				
1	Plug Stem	17-4 PH STAINLESS STEEL H1075 ⁽¹⁾				
		SOLUTION ANNEALED 316 STAINLESS STEEL				
		HARDENED ASTM A638 GRADE 660				
		ASTM B637 ALLOY				
2	Packing Flange Stud	ASTM A193 GRADE B8 CLASS 1				
3	Packing Flange Nut	ASTM A194 GRADE 8				
4	Packing Flange	ASTM A216 GRADE WCC ZINC PLATING				
5	Packing Follower	AUSTENITIC STAINLESS STEEL				
6	Packing	PTFE PACKING / LE PACKING	FLEXIBLE GRAPHITE PACKING			
		PTFE PACKING / LE* PACKING WITH EXTENSION BONNET				
7	Lantern Ring (Optional)	AUSTENITIC STAINLESS STEEL				
8	Valve Bonnet	ASTM A216 GRADE WCC/WCB/EN 1.0619/1.0625 or A105				
9	Body Stud	ASTM A193 GRADE B7				
10	Body Stud Nut	ASTM A194 GRADE 2H				
11	Body Gasket	316L ST ST SPIRAL WOUND GASKET WITH GRAPHITE FILLER				
12	Guide Bushing ⁽⁶⁾	HARDENED 440C STAINLESS STEEL ⁽²⁾				
		Stellite or Equivalent NO. 6				
13	Cage / Retainer ⁽⁴⁾	SOLUTION ANNEALED 304 STAINLESS STEEL				
		CA6NM CLASS B STAINLESS STEEL ⁽³⁾				
	Close Clearance Cage/Seat	SOLUTION ANNEALED 316 STAINLESS STEEL				
		HARDENED 410 STAINLESS STEEL				
Stellite or Equivalent NO. 6						
14	Seat Ring	SOLUTION ANNEALED 316 STAINLESS STEEL				
		HARDENED 410 STAINLESS STEEL				
		316 STAINLESS STEEL WITH Stellite or Equivalent NO. 6 HARDFACING				
		HARDENED 440C STAINLESS STEEL (from 0.75" to 3" only)				
15	Seat Ring Gasket	316L ST ST SPIRAL WOUND GASKET WITH GRAPHITE FILLER				
16	Plug	SOLUTION ANNEALED 316 STAINLESS STEEL				
		SOLUTION ANNEALED 316 SS W/ TEFLON SEAT				
		HARDENED 410 STAINLESS STEEL				
		316 STAINLESS STEEL WITH Stellite or Equivalent NO. 6 HARDFACING ON SEAT ⁽⁶⁾				
		316 STAINLESS STEEL WITH Stellite or Equivalent NO. 6 HARDFACING ON SEAT AND GUIDE ⁽⁵⁾				
	Stellite or Equivalent NO. 6 ⁽⁷⁾					
	Close Clearance Plug	Stellite or Equivalent NO. 6 ⁽⁷⁾				
17	Plug Pin	SOLUTION ANNEALED 316 STAINLESS STEEL				
18	Valve Body	ASTM A216 GRADE WCC/WCB / EN 1.0619/1.0625				
19	Drive Nut	LOW CARBON STEEL GRADES DICHROMATE ZINC PLATED				
Ref. No.	Temperature Range	-20°F (-29°C)	450°F (232°C)	650°F (343°C)	800°F (427°C)	

1) 17-4 PH ST.ST will be substituted when required due to the differential pressure.

2) 440C bushing not used in combination with 316 trim.

3) Standard material for two stage lo-db (drilled hole) cages.

4) Required for Quick Change trim only.

5) Use Solid Stellite or Equivalent plug for C_v smaller than 1.7.

6) Guide bushings not used with close clearance trim.

7) Solid Stellite or Equivalent is not available for Lo-dB/Anti-Cavitation plugs.

Materials of Construction

Standard Stainless Steel Version

Ref. No.	Temperature Range	-20°F (-29°C)	450°F (232°C)	650°F (343°C)	800°F (427°C)
	Description	Standard Materials			
1	Plug Stem	SOLUTION ANNEALED 316 STAINLESS STEEL			
		HARDENED ASTM A638 GRADE 660			
		ASTM B637 ALLOY			
2	Packing Flange Stud	ASTM A193 GRADE B8 CLASS 1			
3	Packing Flange Nut	ASTM A194 GRADE 8			
4	Packing Flange	ASTM A216 GRADE WCC ZINC PLATING			
5	Packing Follower	AUSTENITIC STAINLESS STEEL			
6	Packing	PTFE PACKING / LE PACKING		FLEXIBLE GRAPHITE PACKING	
		PTFE PACKING / LE PACKING WITH EXTENSION BONNET			
7	Lantern Ring (Optional)	AUSTENITIC STAINLESS STEEL			
8	Valve Bonnet	ASTM A351 GRADE CF8M			
9	Body Stud	ASTM A193 GR B7 – ZINC PLATING		ASTM A193 GRADE B7	
10	Body Stud Nut	ASTM A194 GR 2H – ZINC PLATING		ASTM A194 GRADE 2H	
11	Body Gasket	316L ST ST SPIRAL WOUND GASKET WITH GRAPHITE FILLER			
12	Guide Bushing ⁽⁴⁾	NITRONIC 60 ASTM A479			
		Stellite or Equivalent NO. 6			
13	Cage / Retainer ⁽¹⁾	SOLUTION ANNEALED 304 STAINLESS STEEL			
		CA6NM CLASS B STAINLESS STEEL ⁽²⁾			
	Close Clearance Cage/Seat	SOLUTION ANNEALED 316 STAINLESS STEEL			
		HARDENED 410 STAINLESS STEEL			
		Stellite or Equivalent NO. 6			
14	Seat Ring	SOLUTION ANNEALED 316 STAINLESS STEEL			
		316 STAINLESS STEEL WITH Stellite or Equivalent NO. 6 HARDFACING			
15	Seat Ring Gasket	316L ST ST SPIRAL WOUND GASKET WITH GRAPHITE FILLER			
16	Plug	SOLUTION ANNEALED 316 STAINLESS STEEL			
		SOLUTION ANNEALED 316 SS W/ TEFLON SEAT			
		HARDENED 410 STAINLESS STEEL			
		316 STAINLESS STEEL WITH Stellite or Equivalent NO. 6 HARDFACING ON SEAT ⁽³⁾			
		316 STAINLESS STEEL WITH Stellite or Equivalent NO. 6 HARDFACING ON SEAT AND GUIDE ⁽³⁾			
			Stellite or Equivalent NO. 6 ⁽⁵⁾		
	Close Clearance Plug	Stellite or Equivalent NO. 6 ⁽⁵⁾			
17	Plug Pin	SOLUTION ANNEALED 316 STAINLESS STEEL			
18	Valve Body	ASTM A351 GRADE CF8M			
19	Drive Nut	ASTM A216 GRADE WCC			
Ref. No.	Temperature Range	-20°F (-29°C)	450°F (232°C)	650°F (343°C)	800°F (427°C)

- 1) Required for Quick Change trim only.
- 2) Standard material for two stage lo-db (drilled hole) cages.
- 3) Use Solid Stellite or Equivalent plug for C_v smaller than 1.7.
- 4) Guide bushings not used with close clearance trim.
- 5) Solid Stellite or Equivalent is not available for Lo-dB/Anti-Cavitation plugs.

Materials of Construction

Standard Chrome Moly Version

Ref. No.	Temperature Range	-20°F (-29°C)	450°F (232°C)	650°F (343°C)	800°F (427°C)	
	Description	Materials				
1	Plug Stem	17-4 PH STAINLESS STEEL H1075 ⁽¹⁾				
		SOLUTION ANNEALED 316 STAINLESS STEEL				
		HARDENED ASTM A638 GRADE 660				
		ASTM B637 ALLOY				
2	Packing Flange Stud	ASTM A193 GRADE B8 CLASS 1				
3	Packing Flange Nut	ASTM A194 GRADE 8				
4	Packing Flange	ASTM A216 GRADE WCC ZINC PLATING				
5	Packing Follower	AUSTENITIC STAINLESS STEEL				
6	Packing	PTFE PACKING / LE* PACKING		FLEXIBLE GRAPHITE PACKING		
		PTFE PACKING / LE* PACKING WITH EXTENSION BONNET				
7	Lantern Ring (Optional)	AUSTENITIC STAINLESS STEEL				
8	Valve Bonnet	ASTM A217 GRADE WC9 CLASS 3				
9	Body Stud	ASTM A193 GRADE B7				
10	Body Stud Nut	ASTM A194 GRADE 2H				
11	Body Gasket	316L ST ST SPIRAL WOUND GASKET WITH GRAPHITE FILLER				
12	Guide Bushing ⁽⁵⁾	HARDENED 440C STAINLESS STEEL				
		Stellite or Equivalent NO. 6				
		SOLUTION ANNEALED 304 STAINLESS STEEL				
13	Cage / Retainer ⁽²⁾	SOLUTION ANNEALED 304 STAINLESS STEEL				
		CA6NM CLASS B STAINLESS STEEL ⁽³⁾				
	Close Clearance Cage/Seat	SOLUTION ANNEALED 316 STAINLESS STEEL				
		HARDENED 410 STAINLESS STEEL				
		Stellite or Equivalent NO. 6				
14	Seat Ring	SOLUTION ANNEALED 316 STAINLESS STEEL				
		HARDENED 410 STAINLESS STEEL				
		316 STAINLESS STEEL WITH Stellite or Equivalent NO. 6 HARDFACING				
15	Seat Ring Gasket	316L ST ST SPIRAL WOUND GASKET WITH GRAPHITE FILLER				
16	Plug	SOLUTION ANNEALED 316 STAINLESS STEEL				
		SOLUTION ANNEALED 316 SS W/ TEFLON SEAT				
		HARDENED 410 STAINLESS STEEL				
		316 STAINLESS STEEL WITH Stellite or Equivalent NO. 6 HARDFACING ON SEAT ⁽⁴⁾				
		316 STAINLESS STEEL WITH Stellite or Equivalent NO. 6 HARDFACING ON SEAT AND GUIDE ⁽⁴⁾				
	Stellite or Equivalent NO. 6 ⁽⁶⁾					
	Close Clearance Plug	Stellite or Equivalent NO. 6 ⁽⁶⁾				
17	Plug Pin	SOLUTION ANNEALED 316 STAINLESS STEEL				
18	Valve Body	ASTM A217 GRADE WC9 CLASS 3				
19	Drive Nut	ASTM A216 GRADE WCC				
Ref. No.	Temperature Range	-20°F (-29°C)	450°F (232°C)	650°F (343°C)	800°F (427°C)	

1) 17-4 PH ST.ST will be substituted when required due to the differential pressure.

2) Required for Quick Change trim only.

3) Standard material for two stage Lo-db* (drilled hole) cages.

4) Use Solid Stellite or Equivalent plug for C_v smaller than 1.7.

5) Guide bushings not used with close clearance trim.

6) Solid Stellite or Equivalent is not available for Lo-db/Anti-Cavitation plugs.

Materials of Construction

NACE Materials Construction

Ref. No.	Temperature Range	-20°F (-29°C)	450°F (232°C)
	Description	NACE Materials ⁽¹⁾	
1	Plug Stem	SOLUTION ANNEALED 316 STAINLESS STEEL	
		ASTM B637 ALLOY ⁽²⁾	
2	Packing Flange Stud	ASTM A193 GRADE B8 CLASS 1 ⁽³⁾	
		ASTM A193 GR B7M ZINC PLATING ⁽⁴⁾	
3	Packing Flange Nut	ASTM A194 GRADE 8 ⁽³⁾	
		ASTM A194 GR 2HM ZINC PLATING ⁽⁴⁾	
4	Packing Flange	ASTM A216 GRADE WCC ZINC PLATING	
5	Packing Follower	SOLUTION ANNEALED 304 STAINLESS STEEL	
6	Packing	PTFE PACKING / LE PACKING	
7	Lantern Ring (Optional)	SOLUTION ANNEALED 304 STAINLESS STEEL	
8	Valve Bonnet	ASTM A216 GRADE WCC	
		ASTM A105	
		ASTM A351 GRADE CF8M	
9	Body Stud	ASTM A193 GR B7 – ZINC PLATING ^{(3) (7)}	
		ASTM A193 GR B7M ZINC PLATING ^{(4) (7)}	
		ASTM A193 GRADE B7 ⁽³⁾	
		ASTM A193 GRADE B7M ⁽⁴⁾	
10	Body Stud Nut	ASTM A194 GR 2H – ZINC PLATING ^{(3) (7)}	
		ASTM A194 GR 2HM ZINC PLATING ^{(4) (7)}	
		ASTM A194 GRADE 2H ⁽³⁾	
		ASTM A194 GRADE 2HM ⁽⁴⁾	
11	Body Gasket	316L ST ST SPIRAL WOUND GASKET WITH GRAPHITE FILLER	
12	Guide Bushing ⁽⁸⁾	Stellite or Equivalent NO. 6	
13	Cage / Retainer ⁽⁴⁾	SOLUTION ANNEALED 304 STAINLESS STEEL	
	Close Clearance Cage/Seat ⁽⁶⁾	SOLUTION ANNEALED 316 STAINLESS STEEL Stellite or Equivalent NO. 6	
14	Seat Ring	SOLUTION ANNEALED 316 STAINLESS STEEL	
		316 STAINLESS STEEL WITH Stellite or Equivalent NO. 6 HARDFACING	
15	Seat Ring Gasket	316L ST ST SPIRAL WOUND GASKET WITH GRAPHITE FILLER	
16	Plug	SOLUTION ANNEALED 316 STAINLESS STEEL	
		316 STAINLESS STEEL WITH Stellite or Equivalent NO. 6 HARDFACING ON SEAT	
		316 STAINLESS STEEL WITH Stellite or Equivalent NO. 6 HARDFACING ON SEAT AND GUIDE	
	Close Clearance Plug	Stellite or Equivalent NO. 6 ^{(6) (9)}	
17	Plug Pin	SOLUTION ANNEALED 316 STAINLESS STEEL	
18	Valve Body	ASTM A216 GRADE WCC	
		ASTM A105	
		ASTM A351 GRADE CF8M	
19	Drive Nut	ASTM A216 GRADE WCC	

1) Materials and processes in accordance with the requirements of NACE specification MR0103. Applications requiring compliance to MR0175, 2003 Rev. or ISO 15156 would require engineering review.

2) Inconel 718 will be substituted in applications when required due to the differential pressure.

3) Materials designated for these parts conform to NACE Class III (unexposed) bolting requirements.

4) Materials designated for these parts conform to NACE Class I or Class II (exposed) bolting requirements.

5) Consult Masoneilan for NACE Applications above ANSI Class 600 (PN 100) rating or above 450°F (232°C).

6) Optional component and materials for Close Clearance low flow trim option.

7) To be used with stainless steel body and bonnet.

8) Guide bushing not used with close clearance trim.

9) Solid Stellite or Equivalent is not available for Lo-dB*/Anti-Cavitation plugs.

Materials of Construction

Cryogenic Construction

Ref. No.	Temperature Range	-320°F (-196°C)	-50°F (-46°C)	-20°F (-29°C)
	Description ⁽³⁾ ⁽⁴⁾	Standard Materials ⁽¹⁾ ⁽²⁾ ⁽⁵⁾		
1	Plug Stem	SOLUTION ANNEALED 316 STAINLESS STEEL		
		HARDENED ASTM A638 GRADE 660		
2	Packing Flange Stud	ASTM A193 GRADE B8 CLASS 1		
3	Packing Flange Nut	ASTM A194 GRADE 8		
4	Packing Flange	ASTM A351 GRADE CF8M		
5	Packing Follower	AUSTENITIC STAINLESS STEEL		
6	Packing	Teflon™ V-Ring		
7	Lantern Ring (Optional)	AUSTENITIC STAINLESS STEEL		
8	Valve Bonnet	ASTM A351 GRADE CF8M [163C](163)		
		ASTM A479 TYPE 316		
		ASTM A352 GRADE LCC		
9	Body Stud ⁽⁶⁾	ASTM A193 GRADE B8 CLASS 2 ($< 3/4"$ Ø) –		
		– $< 3/4"$ Ø OR .75" - 2" Class 150, 300 & 600		
		3" - 4" Class 150 & 300; 3" Class 600 ASTM A453 GRADE 660 CLASS A ($3/4" < \text{Ø} < 1"$)		
		$3/4" < \text{Ø} < 1"$ OR 1.5" - 2" Class 900 / 1500; 1.5" Class 2500 AMS 4676 ($\geq 1"$ Ø) – $> 1"$ Ø OR .75" - 1" Class 900 / 1500 & 2500		
10	Body Stud Nut	4" - 6" Class 600; 2" Class 2500		
11	Body Gasket	ASTM A194 GRADE 8		
12	Guide Bushing	316L ST ST SPIRAL WOUND GASKET WITH GRAPHITE FILLER		
		Stellite or Equivalent NO. 6 (STANDARD)		
13	Cage	NITRONIC 60 ASTM A479 (OPTIONAL)		
		SOLUTION ANNEALED 304 STAINLESS STEEL (STANDARD)		
14	Seat Ring	SOLUTION ANNEALED 316 STAINLESS STEEL (OPTIONAL)		
		SOLUTION ANNEALED 316 STAINLESS STEEL		
15	Seat Ring Gasket	316 STAINLESS STEEL WITH Stellite or Equivalent NO. 6 HARDFACING		
16	Plug	316L ST ST SPIRAL WOUND GASKET WITH GRAPHITE FILLER		
		SOLUTION ANNEALED 316 STAINLESS STEEL		
17	Plug Pin	316 STAINLESS STEEL WITH Stellite or Equivalent NO. 6 HARDFACING ON SEAT		
18	Valve Body	SOLUTION ANNEALED 316 STAINLESS STEEL		
		ASTM A351 GRADE CF8M		
19	Drive Nut	ASTM A352 GRADE LCC		
Ref. No.	Temperature Range	-320°F (-196°C)	-50°F (-46°C)	-20°F (-29°C)

1) Materials recommended for Cryogenic Liquid Natural Gas (LNG) applications -320°F (-196°C).

Consult factory for suitability in other cryogenic applications.

2) Consult factory for NACE applications.

3) Trim offerings limited to Quick Change designs only.

4) Consult factory for proper actuator sizing to provide correct valve shut-off.

5) JIS and EN material equivalents are available.

6) Body stud materials also satisfy the requirements of the pressure equipment directive 97/23/EC.

Bellows Seal Design Features 21000 BS Series

Standard Construction

Bellows seal configuration is fully compatible with the standard 21000 Series trim and actuator options providing equivalent capacity capabilities for each valve size. The standard packing box design and packing design options are used as a secondary stem seal.

Rugged Design

The formed bellows construction is an externally pressurized design that is capable of operating up to the full valve ANSI B16.34 pressure rating. Guides are located above and below the bellows providing excellent stability to withstand flow induced and mechanical vibration.

Extended Life

The bellows assembly is designed for 50% compression/extension (zero stress) at the valve mid-stroke position to help maximize cycle life. Bellows torsional stresses are also reduced with the anti-rotation feature provided by flats on the plug stem.

High Quality

Each bellows subassembly is helium leak tested to verify weld integrity, and is also hydro-statically tested as part of the complete valve assembly. Mechanical travel stops are also designed into both the bellows and valve assemblies to prevent over compression or extension.

Smart Solution

Bellows installed cycle life can be monitored in the field by utilizing Masoneilan's SVI* Digital Positioner with actual process data. This advanced preventative maintenance option will help improve plant safety by identifying potential hazardous failures before they happen, and cut cost by reducing premature bellows replacement.

Bellows Materials Standard Material

316/316L Stainless Steel

Optional Materials

Hastelloy C276

Monel 400

Inconel 625

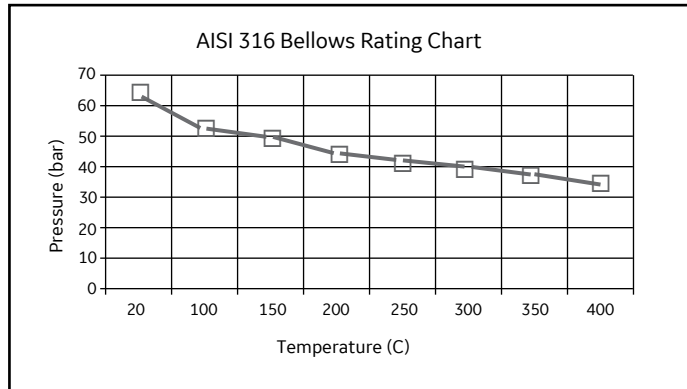

Size and Ratings

Pressure Ratings: ASME Class 150 and 300 – PN 20 and PN 50

Valve Size	Bellows Design Stroke		Life Cycle Ratings ⁽¹⁾		
	Inches	mm	100%	50%	25%
.75"-2"	75	19	100,000 Full Cycles	600,000 Full Cycles	3,000,000 Full Cycles
3"-4"	1.50	38.1			
6"	2.00	50.8			

(1) Minimum expected average cycle life for Class 300 (PN 50) bellows operating at constant pressure.

(2) Consult Masoneilan for Bellows applications above ASME Class 300 (PN 50).

Materials of Construction

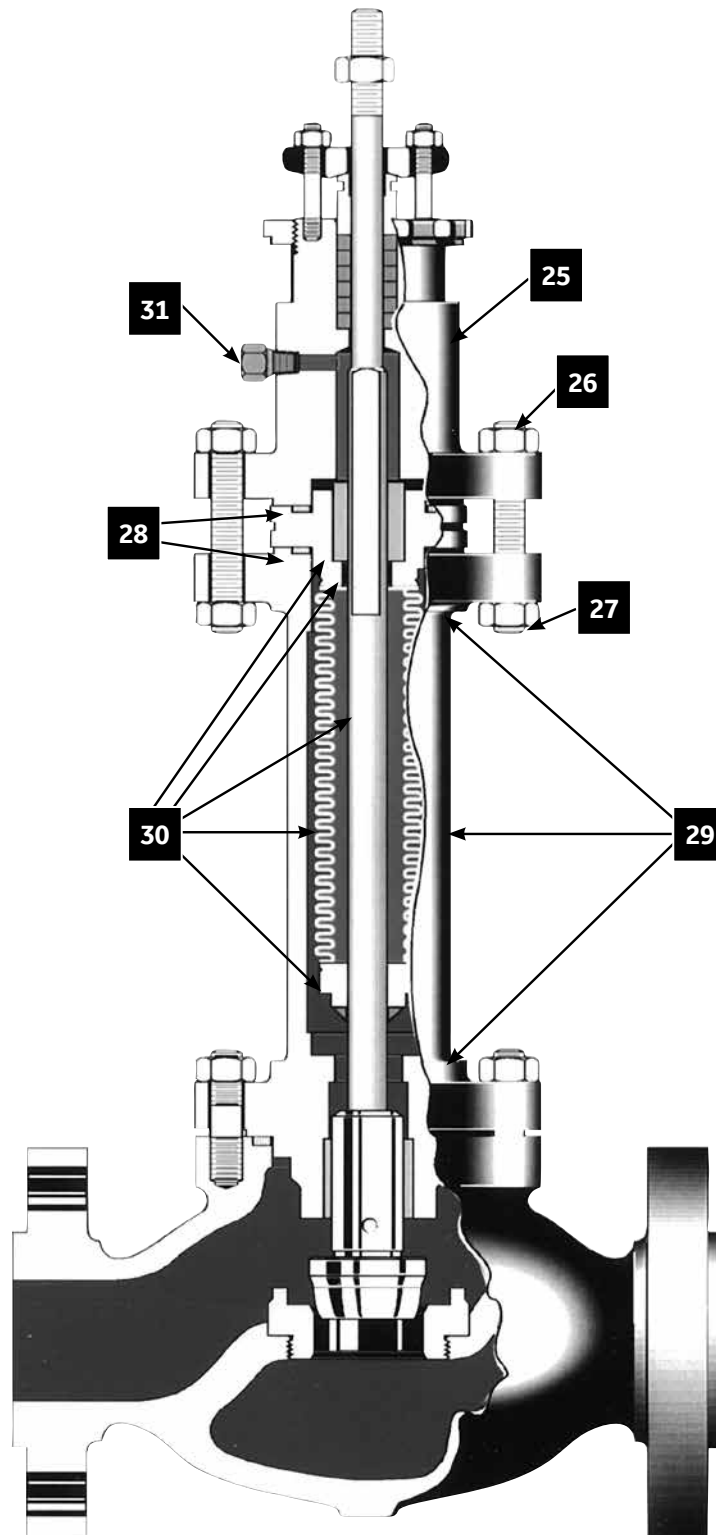

Bellows Seal Construction

Materials of Construction

Bellows Seal - Carbon Steel Body Version ⁽¹⁾

Ref. No.	Temperature Range		-20°F (-29°C)	800°F (427°C)
	Description		Materials	
25	Valve Bonnet		ASTM A216 GRADE WCC or ASTM A105	
26	Bonnet Stud		ASTM A193 GRADE B7	
27	Bonnet Stud Nut		ASTM A194 GRADE 2H	
28	Bonnet Spacer Gasket		316L ST ST SPIRAL WOUND GASKET WITH GRAPHITE FILLER	
29	Carbon Steel Bonnet Extension Assembly	Upper Flange	ASTM A216 GRADE WCC or ASTM A105	
		Spacer	ASTM A106 GRADE B HRC 22 MAXIMUM	
		Lower Flange	ASTM A216 GRADE WCC	
30	Stainless Steel Bellows and Stem Assembly	Stem	SOLUTION ANNEALED 316 STAINLESS STEEL	
		Guide Bushing	ASTM A479	
		Bellows	316 ST. ST. ASTM A240/A312	
		Upper Adapter Lower Adapter	GENERAL SERVICE ANNEALED 316L ST ST	
	Hastelloy C ⁽³⁾ Bellows and Stem Assembly	Stem	ASTM B574	
		Guide Bushing	Stellite or Equivalent NO. 6	
		Bellows	Hastelloy C276 ASTM B575/B622	
		Upper Adapter Lower	ASTM B574	
	Monel 400 ⁽³⁾ Bellows and Stem Assembly	Stem	ASTM B164 CLASS A	
		Guide Bushing	Stellite or Equivalent NO. 6	
		Bellows	ASTM B164 CLASS A	
		Upper Adapter Lower	ASTM B164 CLASS A	
Inconel 625 ⁽³⁾ Bellows and Stem Assembly	Stem	INCONEL X-750		
	Guide Bushing	Stellite or Equivalent NO. 6		
	Bellows	ASTM B446		
	Upper Adapter Lower	ASTM B446		
31	Plug - 1/8" NPT		ASTM A234 GRADE WPB	
Ref. No.	Temperature Range		-20°F (-29°C)	800°F (427°C)

(1) Materials for other components are same as listed for Standard Carbon Steel Construction.

(2) Items No. 1 (plug stem) and 8 (bonnet) in Standard Materials of Construction tables are replaced by items above.

(3) Optional Hastelloy C, Monel 400 and Inconel 625 Bellows Construction available.

Materials of Construction

Bellows Seal - Stainless Steel Body Version ⁽¹⁾

Ref. No.	Temperature Range		-20°F (-29°C)	650°F (343°C)	800°F (427°C)
	Description		Materials		
25	Valve Stud		ASTM A351 GRADE CF8M or ASTM A182 GRADE F 316		
26	Bonnet Stud		ASTM A193 GR B7 - ZINC PLATING	ASTM A193 GRADE B7	
27	Bonnet Stud Nut		ASTM A194 GR 2H - ZINC PLATING	ASTM A194 GRADE 2H	
28	Bonnet Spacer Gasket		316L ST ST SPIRAL WOUND GASKET WITH GRAPHITE FILLER		
29	Carbon Steel Bonnet Extension Assembly	Upper Flange	ASTM A351 GRADE CF8M or ASTM A182 GRADE F 316		
		Spacer	316 St. St. ASTM A269 TY 316		
		Lower Flange	ASTM A351 GRADE CF8M		
30	Stainless Steel Bellows and Stem Assembly	Stem	SOLUTION ANNEALED 316 STAINLESS STEEL		
		Guide Bushing	ASTM A479		
		Bellows	316 St. St. ASTM A240/A312		
		Upper Adapter Lower Adapter	GENERAL SERVICE ANNEALED 316L ST ST		
	Hastelloy C ⁽³⁾ Bellows and Stem Assembly	Stem	ASTM B574		
		Guide Bushing	Stellite or Equivalent NO. 6		
		Bellows	Hastelloy C276 ASTM B575/B622		
		Upper Adapter Lower	ASTM B574		
	Monel 400 ⁽³⁾ Bellows and Stem Assembly	Stem	ASTM B164 CLASS A		
		Guide Bushing	Stellite or Equivalent NO. 6		
		Bellows	ASTM B164 CLASS A		
		Upper Adapter Lower	ASTM B164 CLASS A		
Inconel 625 ⁽³⁾ Bellows and Stem Assembly	Stem	INCONEL X-750			
	Guide Bushing	Stellite or Equivalent NO. 6			
	Bellows	ASTM B446			
	Upper Adapter Lower	ASTM B446			
31	Plug - 1/8" NPT		AUSTENITIC STAINLESS STEEL		
Ref. No.	Temperature Range		-20°F (-29°C)	650°F (343°C)	800°F (427°C)

(1) Materials for other components are same as listed for Standard Stainless Steel Construction.

(2) Items No. 1 (plug stem) and 8 (bonnet) in Standard Materials of Construction tables are replaced by items above.

(3) Optional Hastelloy C, Monel 400 and Inconel 625 Bellows Construction available.

Dimensions (inches)

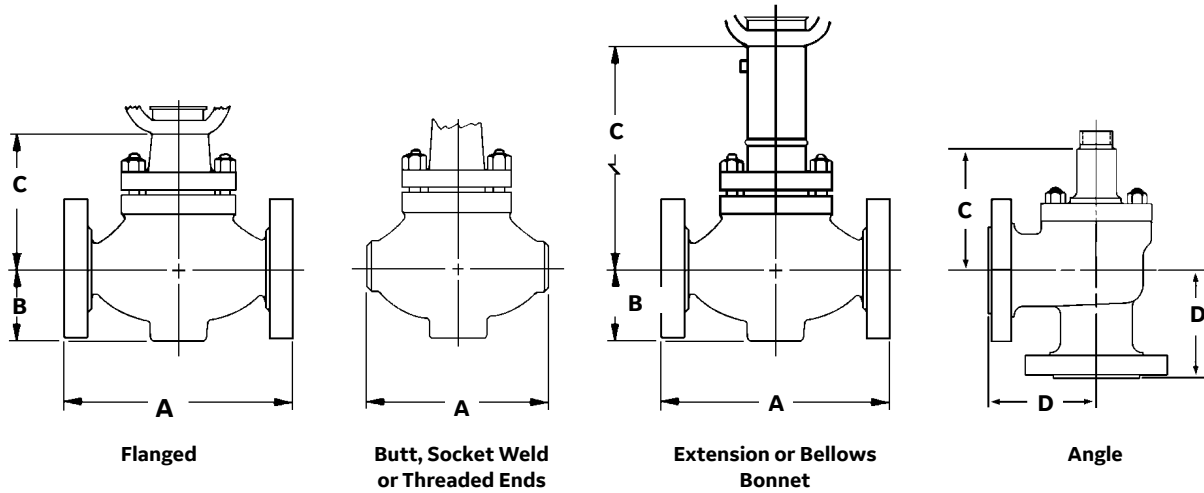

21000 Series Dimensions (inches)

Valve Size (inches)	A															
	ASME Class 150-600 (PN 20-100)	ASME Class 900-1500 (PN 150-250)	ASME Class 2500 (PN 420)	ASME Class 150 (PN 20)	ASME Class 300 (PN 50)	ASME Class 600 (PN 100)	ASME Class 900 (PN 150)	ASME Class 1500 (PN 250)	ASME Class 2500 (PN 420)							
	BW, SW, THD	BW, SW, THD	BW, SW, THD	RF	RF	RTJ	RF	RTJ	RF	RTJ	RF	RTJ	RF	RTJ	RF	RTJ
0.75	8.25	8.50	12.50	7.25	7.63	8.11	8.11	8.11	10.75	10.75	10.75	10.75	12.12	12.12		
1	8.25	8.50	12.50	7.25	7.75	8.25	8.25	8.25	11.50	11.50	11.50	11.50	12.50	12.50		
1.5	9.88	9.25	13	8.75	9.25	9.76	9.88	9.88	13.12	13.12	13.12	13.12	14.12	14.25		
2	11.25	11.50	14.75	10	10.50	11.12	11.25	11.38	14.75	14.88	14.75	14.88	16.25	16.37		
3	13.24	12.50		11.75	12.50	13.12	13.25	13.38	15.24	15.31	15.99	16.06				
4	15.50	14.49		13.88	14.50	15.12	15.50	15.62	18.27	18.34	19.02	19.09				
6	20			17.75	18.62	19.25	20	20.12								
8	24			21.38	22.36	22.83	24	24.09								

Valve Size (inches)	B												
	ANSI Class 150-300 (PN 20-50)	ANSI Class 600 (PN 100)	ANSI Class 150-600 (PN 20-100)	ANSI Class 900-1500 (PN 150-250)		ANSI Class 2500 (PN 420)		ANSI Class 150 (PN 20)	ANSI Class 300 (PN 50)	ANSI Class 600 (PN 100)	ANSI Class 900 (PN 150)	ANSI Class 1500 (PN 250)	ANSI Class 2500 (PN 420)
	BW	BW	SW & THD	BW	SW	BW	SW	RF	RF & RTJ	RF & RTJ	RF & RTJ	RF & RTJ	RF & RTJ
0.75			1.83		2.15		2.42	2	2.29	2.29	2.59	2.59	2.79
1			1.83		2.15		2.42	2.19	2.49	2.49	2.98	2.98	3.18
1.5			2.50		2.81		3.17	2.50	3.08	3.08	3.57	3.57	4.06
2	3	3	3	3.53	3.53	3.87	3.87	3	3.28	3.30	4.26	4.26	4.66
3	3.69	3.69		4.36				3.77	4.16	4.16	4.72	5.22	
4	5	5.50		5.75				4.98	5.05	5.50	5.75	6.10	
6	6.26	7.37						6.26	6.36	7.37			
8	7.68	7.68						7.68	7.68	8.27			

Dimensions (inches)

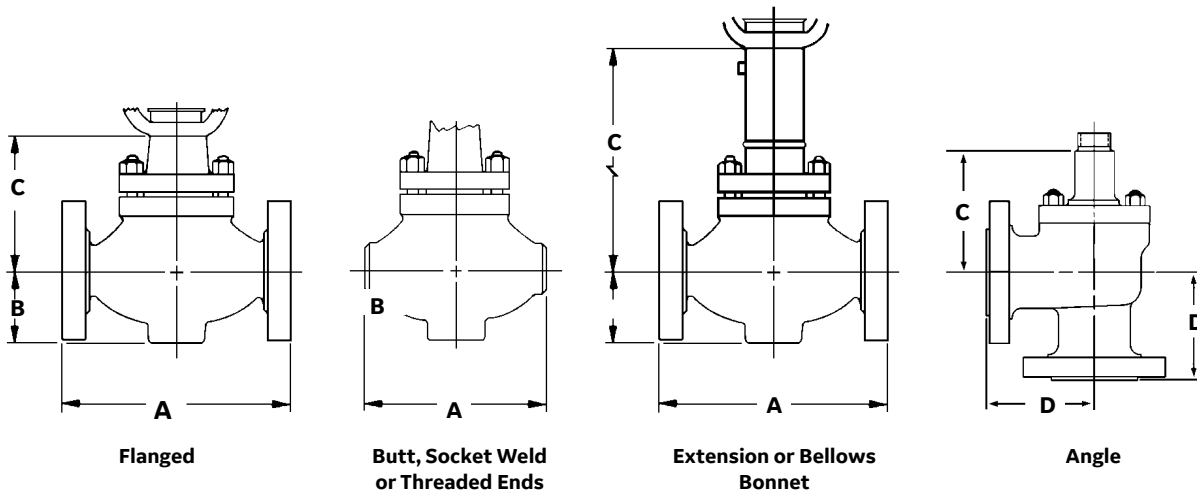

21000 Series Dimensions (inches)

Valve Size (inches)	C											
	Standard Bonnet				Extension Bonnet				Cryogenic Extension Bonnet			Bellows Bonnet
	ASME Class 150-300 (PN 20-50)	ASME Class 600 (PN 100)	ASME Class 900-1500 (PN 150-250)	ASME Class 2500 (PN 420)	ASME Class 150-300 (PN 20-50)	ASME Class 600 (PN 100)	ASME Class 900-1500 (PN 150-250)	ASME Class 2500 (PN 420)	ASME Class 150-600 (PN 20-100)	ASME Class 900-1500 (PN 150-250)	ASME Class 2500 (PN 420)	ASME Class 150-300 (PN 20-50)
0.75	5.65	5.65	7.69	7.69	9.78	9.78	10.76	10.76	23.70	23.80	23.80	16.83
1	5.65	5.65	7.69	7.69	9.78	9.78	10.76	10.76	23.70	23.80	23.80	16.83
1.5	5.51	5.51	9	9	10	10	11.70	11.70	23.70	23.70	23.70	15.22
2	5.51	5.51	9	10.70	10	10	11.70	12.30	23.70	23.70	23.70	15.22
3	8	8	11.35		12.50	12.50	13.70		27.64	27.78		23.75
4	8.05	9.43	14.94		12.56	12.56	17.44		27.64	27.83		23.87
6	11.20	11.13			17.06	16.63			31.84			43.85
8	16.66	16.66			22.78	22.78			34.71			

Valve Size (inches)	D													
	ASME Class 150-600 (PN 20-100)	ASME Class 900-1500 (PN 150-200)	ASME Class 2500 (PN 420)	ASME Class 150 (PN 20)	ASME Class 300 (PN 50)		ASME Class 600 (PN 100)		ASME Class 900 (PN 150)		ASME Class 1500 (PN 250)		ASME Class 2500 (PN 420)	
	BW, SW, THD	BW, SW, THD	BW, SW, THD	RF	RF	RTJ	RF	RTJ	RF	RTJ	RF	RTJ	RF	RTJ
0.75	4.13	4.25	6.25	3.63	3.87	4.13	4.13	4.13	5.38	5.38	5.38	5.38	6.06	6.06
1	4.13	4.25	6.25	3.63	3.87	4.13	4.13	4.13	5.75	5.75	5.75	5.75	6.25	6.25
1.5	4.94	4.63	6.50	4.37	4.63	4.88	4.95	4.94	6.56	6.56	6.56	6.56	7.06	7.12
2	5.63	5.57	7.38	5	5.25	5.56	5.63	5.69	7.37	7.44	7.37	7.44	8.13	8.19
3	6.63			5.87	6.25	6.56	6.63	6.69						
4	7.75			6.94	7.25	7.56	7.75	7.81						
6	10.00			8.87	9.31	9.63	10	10.06						
8														

Dimensions (mm)

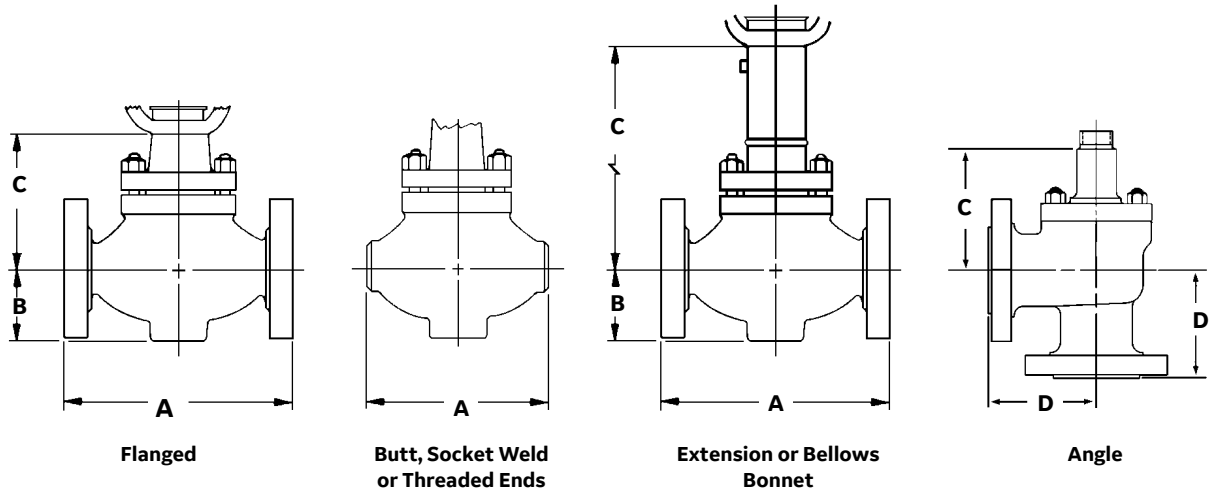

21000 Series Dimensions (mm)

Valve Size (mm)	A													
	ASME Class 150-600 (PN 20-100)	ASME Class 900-1500 (PN 150-250)	ASME Class 2500 (PN 420)	ASME Class 150 (PN 20)	ASME Class 300 (PN 50)		ASME Class 600 (PN 100)		ASME Class 900 (PN 150)		ASME Class 1500 (PN 250)		ASME Class 2500 (PN 420)	
	BW, SW, THD	BW, SW, THD	BW, SW, THD	RF	RF	RTJ	RF	RTJ	RF	RTJ	RF	RTJ	RF	RTJ
20	210	216	318	184	194	206	206	206	273	273	273	273	308	308
25	210	216	318	184	197	210	210	210	292	292	292	292	318	318
40	251	235	330	222	235	248	251	251	333	333	333	333	359	362
50	286	292	375	254	267	283	286	289	375	378	375	378	413	416
80	336	318		299	318	333	337	340	387	389	406	408		
100	394	368		353	368	384	394	397	464	466	483	485		
150	508			451	473	489	508	511						
200	610			543	568	580	610	612						

Valve Size (mm)	B													
	ANSI Class 150-300 (PN 20-50)	ANSI Class 600 (PN 100)	ANSI Class 150-600 (PN 20-100)	ANSI Class 900-1500 (PN 150-250)		ANSI Class 2500 (PN 420)		ANSI Class 150 (PN 20)	ANSI Class 300 (PN 50)	ANSI Class 600 (PN 100)	ANSI Class 900 (PN 150)	ANSI Class 1500 (PN 250)	ANSI Class 2500 (PN 420)	
	BW	BW	SW & THD	BW	SW	BW	SW	RF	RF & RTJ	RF & RTJ	RF & RTJ	RF & RTJ	RF & RTJ	
20			47		55		62	51	58	58	66	66	71	
25			47		55		62	56	63	63	76	76	81	
40			64		72		81	64	78	78	91	91	103	
50	76	76	76	90	90	96	98	76	83	84	108	108	118	
80	95	95		111				96	106	106	120	133		
100	127	140		146				127	128	140	146	155		
150	159	187						159	162	187				
200	195	195						195	195	210				

Dimensions (mm)

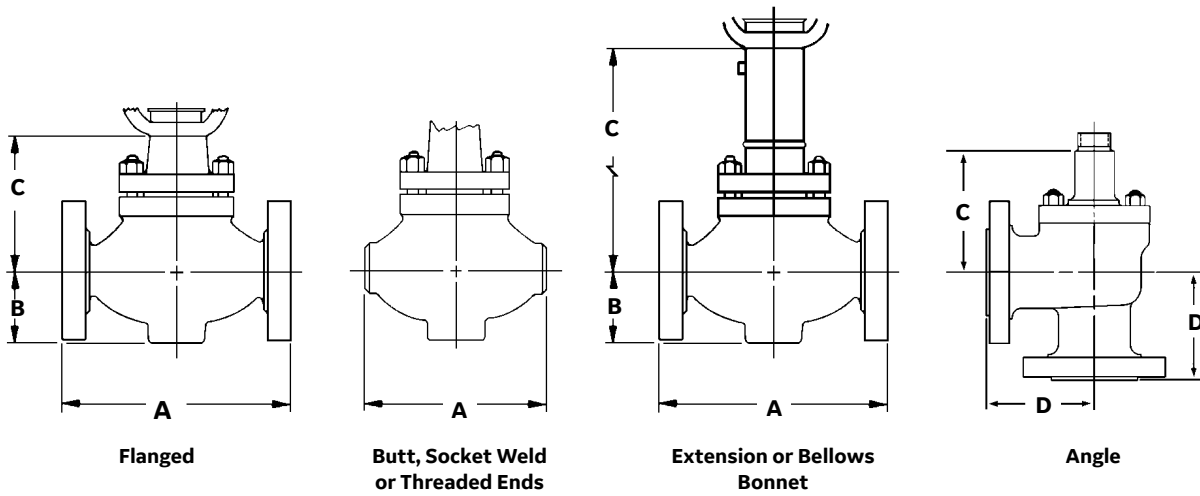

21000 Series Dimensions (mm)

Valve Size (mm)	C											
	Standard Bonnet				Extension Bonnet				Cryogenic Extension Bonnet			Bellows Bonnet
	ASME Class 150-300 (PN 20-50)	ASME Class 600 (PN 100)	ASME Class 900-1500 (PN 150-250)	ASME Class 2500 (PN 420)	ASME Class 150-300 (PN 20-50)	ASME Class 600 (PN 100)	ASME Class 900-1500 (PN 150-250)	ASME Class 2500 (PN 420)	ASME Class 150-600 (PN 20-100)	ASME Class 900-1500 (PN 150-250)	ASME Class 2500 (PN 420)	ASME Class 150-300 (PN 20-50)
20	144	144	195	195	249	249	273	273	602	604	604	427
25	144	144	195	195	249	249	273	273	602	604	604	427
40	140	140	228	228	254	254	297	297	602	602	602	387
50	140	140	228	271	254	254	297	312	602	602	602	387
80	203	203	288		317	317	348		702	706		603
100	205	240	380		319	319	443		702	707		606
150	284	283			424	422			808			1114
200	423	423			579				882			

Valve Size (mm)	D													
	ASME Class 150-600 (PN 20-100)	ASME Class 900-1500 (PN 150-250)	ASME Class 2500 (PN 420)	ASME Class 150 (PN 20)	ASME Class 300 (PN 50)		ASME Class 600 (PN 100)		ASME Class 900 (PN 150)		ASME Class 1500 (PN 250)		ASME Class 2500 (PN 420)	
	BW, SW, THD	BW, SW, THD	BW, SW, THD	RF	RF	RTJ	RF	RTJ	RF	RTJ	RF	RTJ	RF	RTJ
20	105	108	159	92	98	105	105	105	137	137	137	137	154	154
25	105	108	159	92	98	105	105	105	146	146	146	146	159	159
40	126	118	165	111	118	124	126	126	167	167	167	167	179	181
50	143	142	188	127	133	141	143	145	187	189	187	189	206	208
80	168			149	159	167	168	170						
100	197			176	184	192	197	198						
150	254			225	237	244	254	256						
200														

Weights

Body S/A with Standard Bonnet (lbs)

Valve Size (inches)	ASME Class 150 - 300 (PN 20 - 50)		ASME Class 600 (PN 100)		ASME Class 900 - 1500 (PN 150 - 250)		ASME Class 2500 (PN 420)	
	FLG	BW, SW & THD	FLG	BW, SW & THD	FLG	BW, SW & THD	FLG	BW, SW & THD
0.75	36	27	38	27	57	44	70	44
1	36	27	38	27	75	44	90	44
1.5	49	36	53	36	100	57	118	57
2	57	44	64	44	144	82	255	154
3	127	73	128	99	199	146		
4	196	121	216	135	409	318		
6	355	238	450	272				
8	682	610	771	610				

Body S/A with Standard Bonnet (kg)

Valve Size (mm)	ASME Class 150 - 300 (PN 20 - 50)		ASME Class 600 (PN 100)		ASME Class 900 - 1500 (PN 150 - 250)		ASME Class 2500 (PN 420)	
	FLG	BW, SW & THD	FLG	BW, SW & THD	FLG	BW, SW & THD	FLG	BW, SW & THD
20	16	12	17	12	26	20	32	20
25	16	12	17	12	34	20	41	20
40	22	16	24	16	45	26	53	26
50	26	20	29	20	65	37	116	70
80	58	33	58	45	90	66		
100	89	55	98	61	186	144		
150	161	108	204	123				
200	309	277	350	277				

Dimensions and Weights (in./lbs)

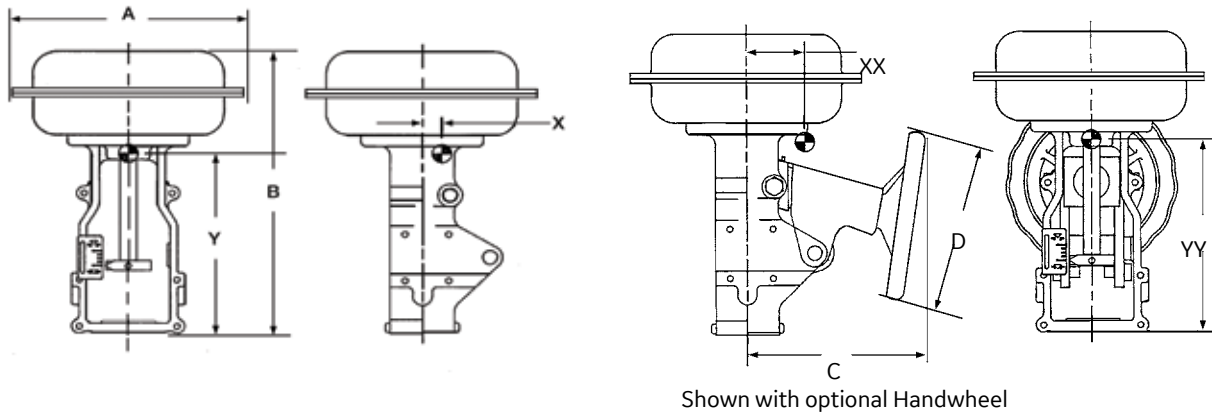

Shown with optional Handwheel

Dimensions and Weights

Actuator Size	Actuator Dimensions (inches)				Weights (lbs.)	
	A	B (Model 88)	C	D	Standard	w/Handwheel
6	11.50	15.54 (17.52)	10.00	9.00	45	60
10	14.50	19.58 (21.54)	10.90	12.00	85	105
16	18.75	28.22 (30.79)	14.00	18.00	210	245
23	23.63	30.71 (33.27)	16.00	18.00	265	320

Actuator Removal Clearance = 6 inches

Center of Gravity (inches)

Without Handwheel

Size	X	Y
6	.19	9.75
10	.0	12.88
16	.13	18.50
23	.06	21.13

With Handwheel

Size	XX	YY
6	1.25	9.13
10	0.88	12.00
16	1.38	16.75
23	1.38	19.00

Limit Stops (inches)

Up Stop

Size	Model	Overall Height B
6	87	19.45
10		25.43
16		36.42
23		38.84
6	88	19.16
10		25.06
16		35.48
23		28.65

Down Stop

Size	Model	Overall Height B
6	87	19.80
10		25.98
16		37.20
23		39.90
6	88	19.74
10		25.85
16		37.46
23		40.33

Dimensions and Weights (mm/kg)

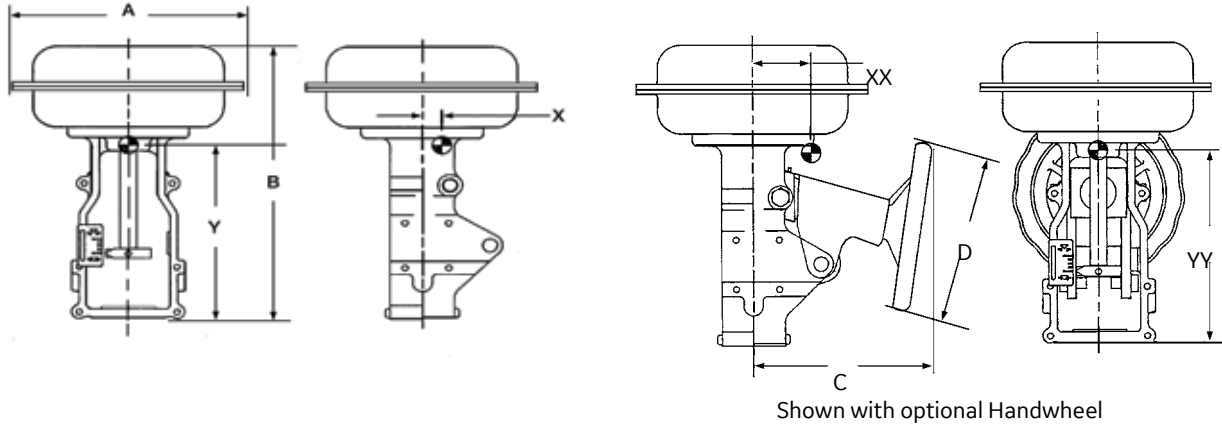

Dimensions and Weights

Actuator Size	Actuator Dimensions (mm)				Weights (kg)	
	A	B (Model 88)	C	D	Standard	w/Handwheel
6	302	395 (445)	254	229	20	27
10	373	497 (547)	277	305	39	48
16	476	717 (782)	356	457	95	111
23	600	780 (845)	406	457	120	145

Actuator Removal Clearance = 152mm

Center of Gravity (mm)

Without Handwheel

Size	X	Y
6	5	248
10	0	327
16	3	470
23	2	537

With Handwheel

Size	XX	YY
6	32	232
10	22	305
16	35	425
23	35	483

Limit Stops (mm)

Up Stop

Size	Model	Overall Height B
6	87	494
10		646
16		925
23		987
6	88	487
10		636
16		901
23		982

Down Stop

Size	Model	Overall Height B
6	87	503
10		660
16		945
23		1014
6	88	501
10		657
16		952
23		1024



FLOCONX[®]
— USA FLOW CONTROL COMPANY —

**FLOCONX LLC
USA FLOW CONTROL COMPANY**

**SALES | INFORMATION
SALES@FLOCONX.COM
VENTAS@FLOCONX.COM**

FLOW CONTROL, OUR PASSION.™

WWW.FLOCONX.COM

**BAKER
HUGHES**
a GE company

